

**Glass ceramic cooktop with sensor control panel in the cooking zone arrangement**  
Width 36" (90 cm)

**CK 494-615**

**Stainless steel frame**

**220-240V / 60Hz**

**CK 494-615**

High user benefits thanks to large distances between pots and pans and sensor electronics.

- **Exclusive stainless steel edges.** Emphasized width.

- **Electronic fine control** without temperature peaks for sensitive dishes.

- **Roaster zone for the large cast-iron roaster BT 481.** Even supply of heat or divide into searing and keeping warm.

One Super Quick cooking zone Ø 7 1/16" (1800 W).

One Super Quick cooking zone Ø 4 3/4" (750 W) converts to Ø 8 1/4" (2200 W).

One Super Quick cooking zone Ø 5 11/16" converts to 5 11/16" - 9 7/16" (2000 W).

Two Super Quick cooking zones Ø 7 1/16" (1800 W) each, convert to a roaster zone 7 1/16" x 16 5/16" (4000 W).

Stainless steel frame.

Integrated touch control panel.

Digital display of cooking zones.

Sensor keys.

Nine-step temperature setting.

Automatic cooking timer.

Automatic quick-boil function for all cooking zones.

Memory function.

Options menu.

Central switch-off device.

Child lock.

Individual residual heat display.

Vacation lock.

**Optional accessories:**

**BT 481-000** Cast roaster made

of aluminum casting with cover, non-stick coating. Cover can also be used as fish or grill pan.

**Planning notes:**

4' 2/3" Power cable (hardware required).

An oven can be installed under the cooktop centrally or to the left.

For installation into natural or synthetic materials, please use Thermostat sealing tape (part no.: 322793).

Below appliance allow 3/8" distance to side wall and intermediate shelf.

Clamping range: 1 9/16" - 2".

Depth of appliance 1 9/16" at control side 2 2/4" (3" x 4").

**Total rating: 10.0 kW**

**Total Amps: 42**

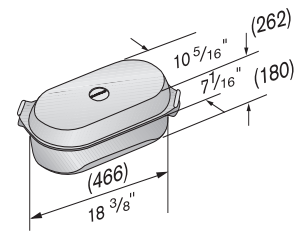

Installation depth in the area of the electrical connection housing 2 9/16".

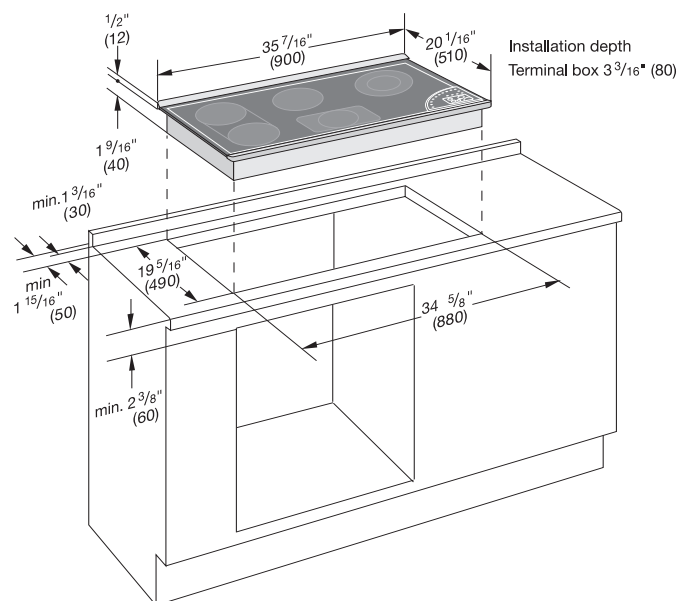

**Numbers indicated inside parenthesis ( ) = mm**