



Stainless

I075WC

1000 SERIES

FEATURES

PERFORMANCE

- Wine bottle capacity of up to 48 bottles (.75L)
- Mechanical controlled triple temperature zone
- Temperature range 40 to 60°F
- Stable, consistent temperatures provide longer term storage capability
- UL residential listing

INTERIOR / EXTERIOR

- Recessed lighting automatically illuminates the white interior when the door is opened
- Solid beech wood trimmed, 3/4 extension black powder coated wine racks
- Standard commercial stainless steel handle is interchangeable with professional handle option on stainless steel model
- Stainless steel model has stainless wrap with black caps on top and bottom to make this unit field reversible
- LowE coated, argon gas filled thermopane glass door provides protection from potentially harmful UV rays and added insulating energy efficiency
- Black vinyl clad textured cabinet is more resistant to scratching, peeling and flaking

INTEGRATION

- Solid beech wood trim on wine racks can be stained to match surrounding cabinetry
- Allow a 2-1/2" clearance on hinged side for 90° door opening when installed adjacent to a wall
- Allow 1/4" width overall for proper installation (see backside for details)
- No additional clearance around sides, top or rear of unit is needed for ventilation
- Do not obstruct front grille air flow
- Durable, factory installed level legs provide a more precise undercounter fit

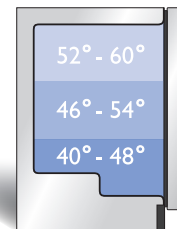

Triple Zone System
featured in I075WC.



For elegant presentation of your wine collection, all U-Line Wine Captain® Models have an illuminated interior.

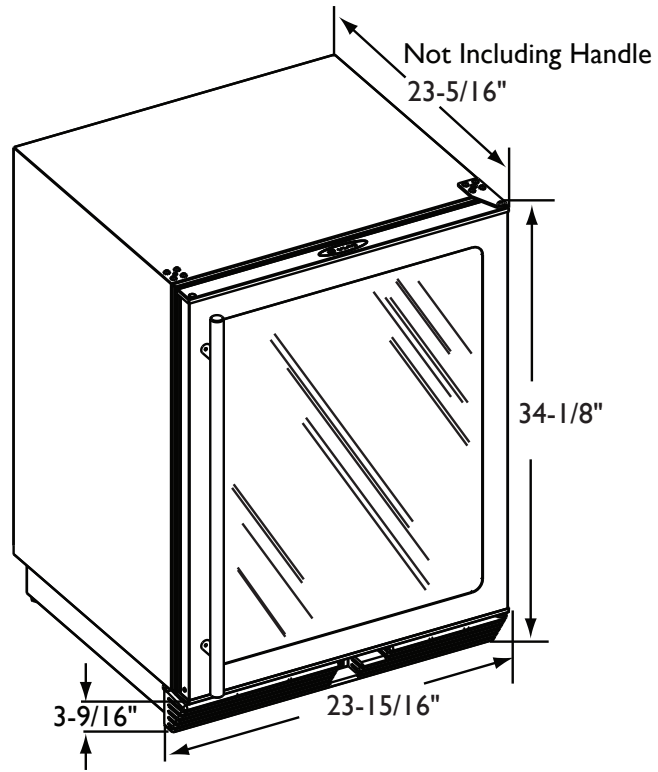

I075WCS Stainless Model

DIMENSIONS AND SPECIFICATIONS

OVERALL DIMENSIONS

Height	34-1/8" (86.6)
Width	23-15/16" (60.8)
Depth	23-5/16" (59.2)
With stainless steel handle	25-3/16" (64.0)
 Shipping weight:	 134 lbs (60 kg)
Running amps	2.4
Maximum start-up amps	9.8
Amps pertain to voltage rating	110/115 volt, 60 Hz
 Capacities:	 Up to 48
Wine bottle storage (0.75L)	

I075WC

Stainless	U-1075WCS-00
-----------	--------------

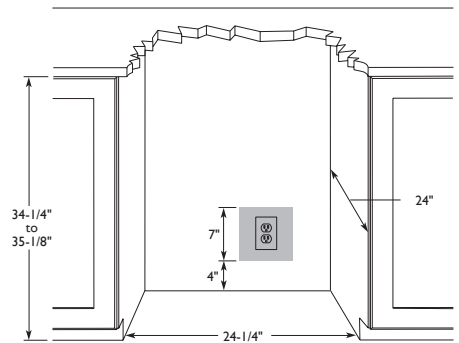

Please visit www.u-line.com for installation guide.
All specifications are subject to change without notice.