

Viking Installation Guide



Built-In Electric Induction Cooktop

Viking Range Corporation
111 Front Street
Greenwood, Mississippi 38930 USA

**IMPORTANT:
PLEASE READ AND FOLLOW**

- Before beginning, please read these instructions completely and carefully.
- Do not remove permanently affixed labels, warnings, or plates from the product. This may void the warranty.
- Please observe all local and national codes and ordinances.
- Please ensure that this product is properly grounded.
- The installer should leave these instructions with the consumer who should retain for local inspector's use and for future reference.
- Installation must conform with local codes or, in the absence of codes, the National Electrical Code, ANSI/NFPA 70-latest edition.

IN CANADA: Electrical installation must be in accordance with the current CSA C22.1 Canadian Electrical Codes Part 1 and/or local codes.

GENERAL INFORMATION

1. **WARNING:** The use of cabinets for storage above the appliance may result in potential burn hazard. Combustible items may ignite, metallic items may become hot and cause burns. If a cabinet storage is to be provided the risk can be reduced by installing a range hood that projects horizontally a minimum of 5 in. beyond the bottom of the cabinets.
2. **WARNING:** This appliance shall not be used for space heating. This information is based on safety considerations.
3. All openings in the wall behind the appliance in the floor under the appliance shall be sealed.
4. Keep appliance area clear and free from combustible materials, gasoline, and other flammable vapors.
5. Disconnect the electric supply to the appliance before cleaning or servicing.
6. When removing the cooktop for service and/or cleaning, disconnect AC power supply.
7. Electrical Requirement:
Listed on Specifications/Wiring Diagram Sheet - Minimum Recommended Electric Circuit.

	WARNING
ELECTRICAL GROUNDING INSTRUCTIONS	
This cooktop must be electrically grounded in accordance with local codes or, in the absence of codes, with the National Electrical Code, ANSI/NFPA 70-latest edition. .	
FOR PERSONAL SAFETY, THIS APPLIANCE MUST BE PROPERLY GROUNDED.	

ELECTRICAL REQUIREMENTS

Check your local codes regarding this unit. This cooktop is supplied with a 3-wire, A.C. 208Y/120 volt or 120/240 volt, 60 HZ electrical system. A white (neutral) is not needed for this unit. See next section for grounding instructions. It should be fused separately.

CAUTION: Be sure the electric power is off from the breaker box to the junction box until the cooktop is installed and ready to operate. The junction box should be connected to a suitable ground.

Refer to the specifications chart for kilowatt rating and recommended amperage. House wiring and fusing must comply with local codes. If no local codes are applicable, wire in accordance with the National Electrical Code, ANSI/NFPA 70-latest edition.

ELECTRICAL CONNECTION

WARNING: The electrical power to the unit must be shut off while line connections are being made. Failure to do so could result in serious injury or death.

When making the wire connections, use the entire length of the conduit provided (3 feet). The conduit must not be cut. Connect the red and black leads from the unit conduit to the corresponding leads in the junction box. The bare ground wire in the conduit is connected to the unit frame. When connecting to a 3-conductor branch circuit, if local codes permit, connect the bare ground connector lead of the unit to the branch circuit neutral (gray or white in color).

DO NOT USE AN EXTENSION CORD WITH THIS APPLIANCE. SUCH USE MAY RESULT IN A FIRE, ELECTRICAL SHOCK OR OTHER PERSONAL INJURY.

SPECIFICATIONS - INDUCTION/RADIANT COOKTOP

Description	30" W. VCCU		36" W. VCCU	
	Cutout Width	Minimum	28 9/16" (72.6 cm)	34 9/16" (87.8 cm)
	Maximum	29 5/8" (75.2 cm)	35 1/2" (90.2 cm)	
Cutout Depth	Minimum - 19 1/8" (48.6 cm)			
	Maximum - 19 7/8" (50.5 cm)			
Overall Width	30 3/4" (78.1 cm)		36 3/4" (93.3 cm)	
Overall Height from Bottom	6 3/4" (17.2 cm)			
Overall Depth from Rear	21" (53.3 cm)			
Electrical Requirements	240 - 208/120 VAC/60 Hz - 3-wire conduit with a No. 10 ground wire.			
Maximum Amp Usage	240V	9.1 kW; 37.9 amps	13.2 kW	55.0 amps
	208V	7.4 kW; 35.4 amps	10.4 kW	50.2 amps
Surface Element Rating		240V	208V	
	Right Front	1800	1560 watts	1800 1560 watts
	Right Rear	3300	2800 watts	3300 2800 watts
	Center Front	N/A	N/A	1800 1350
	Bridge	N/A	N/A	800 600 watts
	Center Rear	N/A	N/A	1800 1350
	Left Front	2500	1875 watts	2200 1650 watts
Left Rear	1500	1125 watts	1500 1125 watts	
Approximate Shipping Weight	52 lb. (23.4 kg)		63 lb. (28.4 kg)	

SPECIFICATIONS - ALL INDUCTION COOKTOP

Description	30" W. VICU		36" W. VICU	
	Cutout Width	Minimum	28 9/16" (72.6 cm)	34 9/16" (87.8 cm)
	Maximum	29 5/8" (75.2 cm)	35 1/2" (90.2 cm)	
Cutout Depth	Minimum - 19 1/8" (48.6 cm)			
	Maximum - 19 7/8" (50.5 cm)			
Overall Width	30 3/4" (78.1 cm)		36 3/4" (93.3 cm)	
Overall Height from Bottom	6 11/16" (17.0 cm)			
Overall Depth from Rear	21" (53.3 cm)			
Electrical Requirements	240 - 208/120 VAC/60 Hz - 3-wire conduit with a No. 10 ground wire.			
Maximum Amp Usage	240V	9.0 kW; 37.5 amps	13.5 kW	56.3 amps
	208V	7.8 kW; 37.5 amps	11.6 kW	56.3 amps
Surface Element Rating		240V	208V	
	Right Front	1200	1040 watts	1200 1040 watts
	Right Rear	3300	2800 watts	3300 2800 watts
	Center Front	N/A	N/A	2700 2340 watts
	Center Rear	N/A	N/A	1800 1560 watts
	Left Front	2700	2340 watts	1800 1560 watts
	Left Rear	1800	1560 watts	2700 2340 watts
Approximate Shipping Weight	52 lb. (23.4 kg)		63 lb. (28.4 kg)	

PROXIMITY TO SIDE CABINET INSTALLATION

1. The cooktop may be installed directly to existing base cabinets.
2. The cooktop CANNOT be installed directly adjacent to sidewalls, tall cabinets, tall appliances, or other side vertical surfaces above 36" (91.4 cm) high. There must be a minimum of 6" (15.2 cm) side clearance from the cooktop to such combustible surfaces above the 36" (91.4 cm).
3. Within the 6" (15.2 cm) side clearance to combustible vertical surfaces above 36" (91.4 cm), the maximum wall cabinet depth must be 13" (33.0 cm) and wall cabinets within this 6" (15.2 cm) side clearance must be 18" (45.7 cm) above the 36" (91.4 cm) high countertop.
4. Wall cabinet above the cooktop must be a minimum of 36" (91.4 cm) above the countertop for a full width of the cooktop.

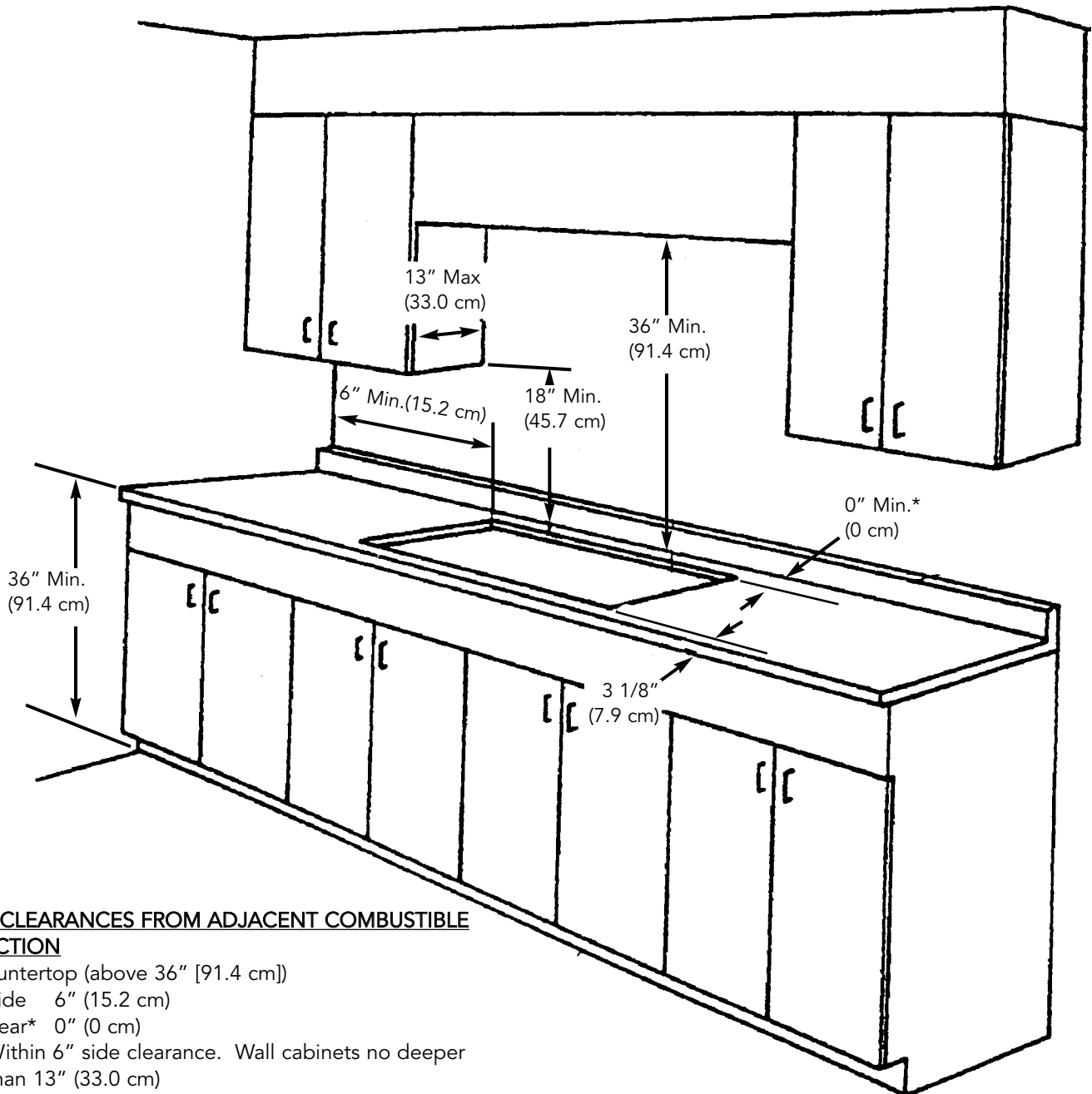

MINIMUM CLEARANCES FROM ADJACENT COMBUSTIBLE CONSTRUCTION

- Above countertop (above 36" [91.4 cm])
 - Side 6" (15.2 cm)
 - Rear* 0" (0 cm)
 - Within 6" side clearance. Wall cabinets no deeper than 13" (33.0 cm)
 - Must be minimum 18" (45.7 cm) above countertop
 - Wall cabinets directly above the product must be minimum 36" (91.4 cm) above the countertop.

***NOTE:** Before cutting countertop cutout, check the inside clearance available from the inside back wall to the proposed placement of the cooktop. A minimum of 1 1/4" (3.2 cm) is required from the back wall of the cooktop to the **inside** wall of the back cabinet. (See page 5) This may require a distance greater than the 0" minimum approved distance.

INTERIOR CABINET CLEARANCES

IMPORTANT: The electronic components for the induction elements in the cooktop need some air circulation. To ensure long life of electronic components, it is required that a minimum of 8" (20.3 cm) open space remain between the bottom of the cooktop and any shelf underneath. The maximum length of the shelf underneath is 18" (45.7cm). There should be no partition or shelf **directly** underneath the unit.

It is also required that the exit air ports at the rear are not blocked. There should be a minimum of 1 1/4" (3.2 cm) space between the exit air ports at the rear of the unit and any nearby obstruction including downdrafts.

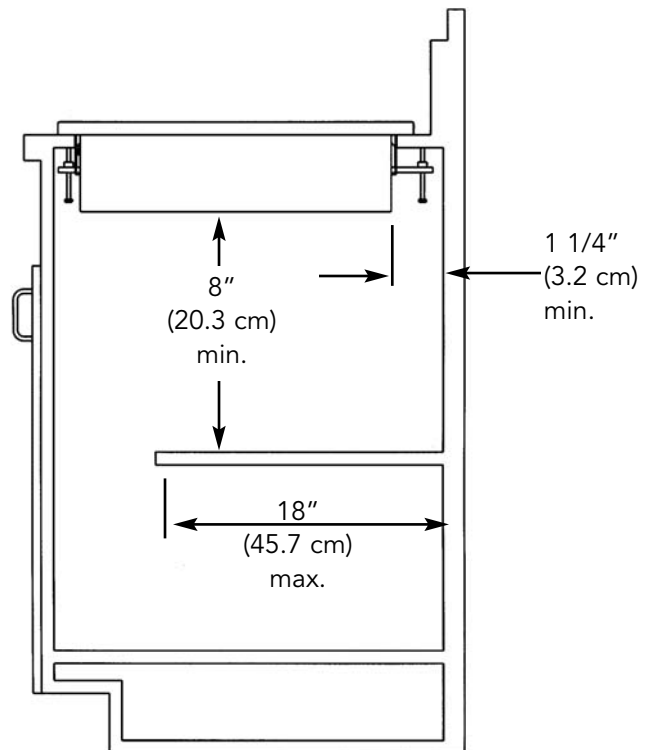

DIMENSIONS INDUCTION/RADIANT COOKTOP

30" W. TOP

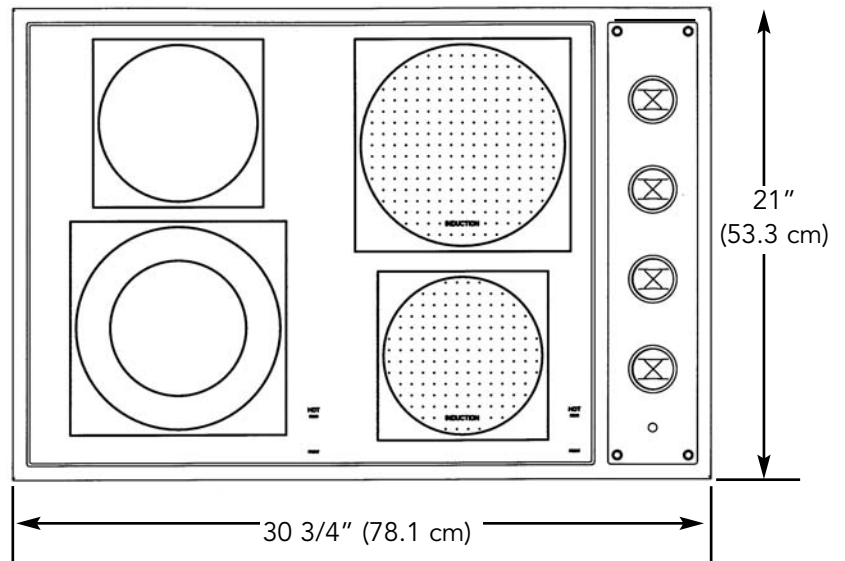

30" W. BURNER BOX

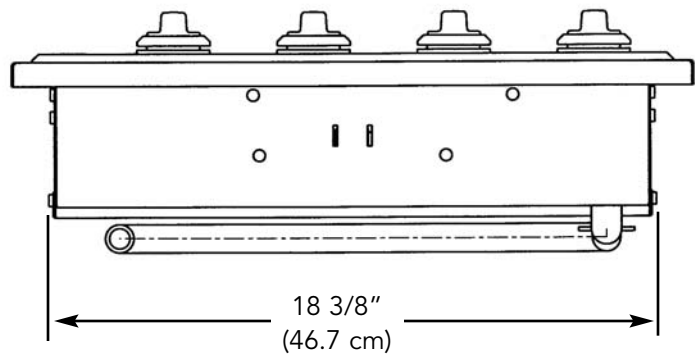

30" W. HEIGHT

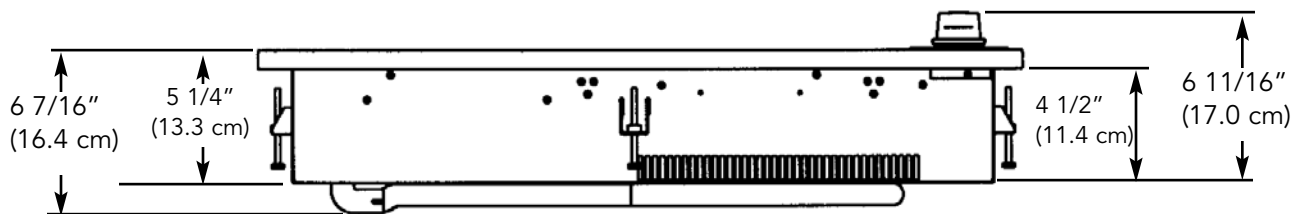

After installation of cooktop, locate the four hold down brackets on each side of the burner box. Screw the sheet metal screw into bracket and tighten firmly against bottom of countertop.

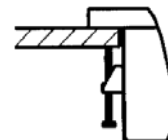

36" W. TOP

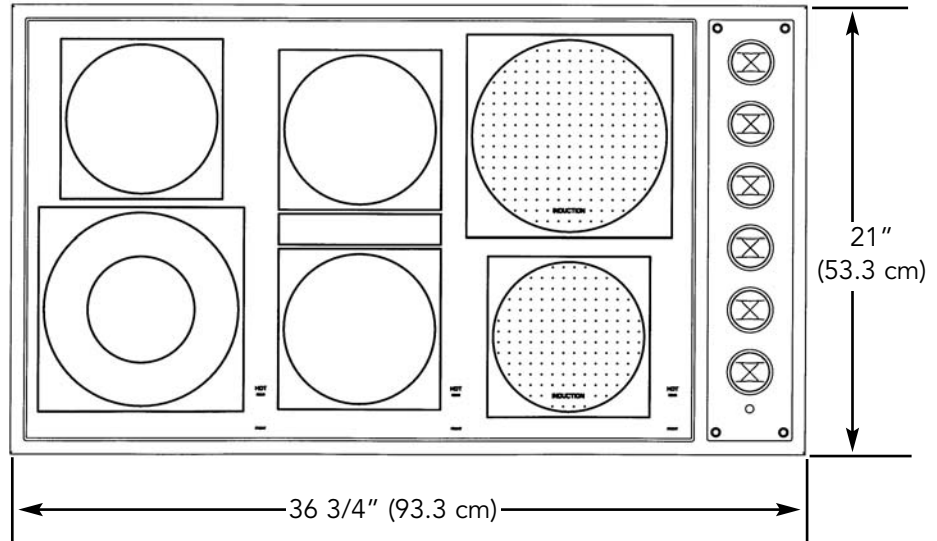

36" W. BURNER BOX

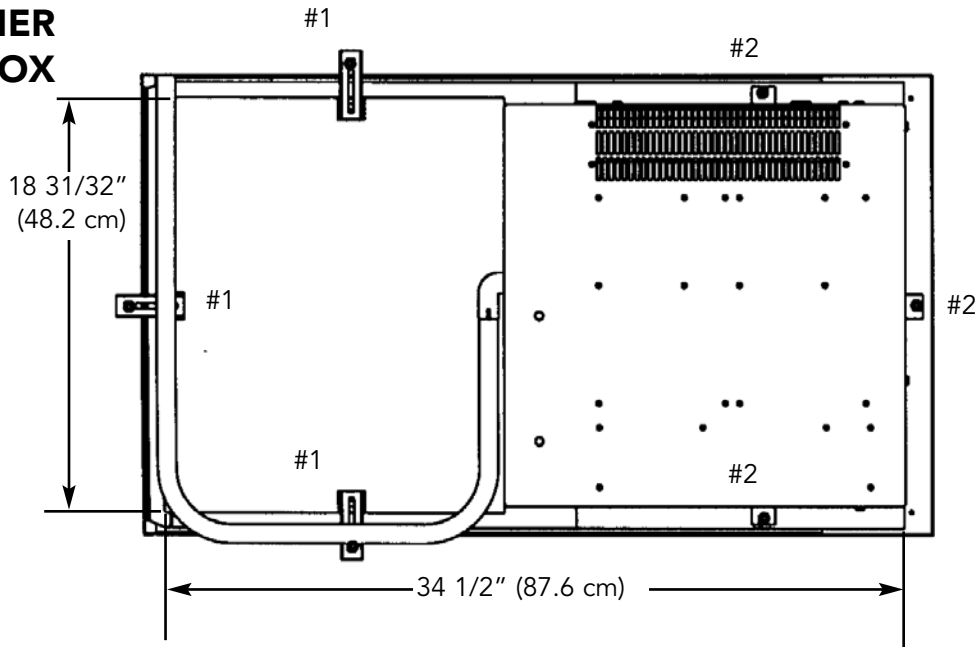

There are two types of hold down brackets on the 36" w. cooktop. After installing cooktop, locate the hold down brackets around the burner box. Brackets #1 are located on the left side of the burner box and brackets #2 are located on the right side of the burner box. Screw the sheet metal screw into the brackets and tighten firmly against bottom of countertop.

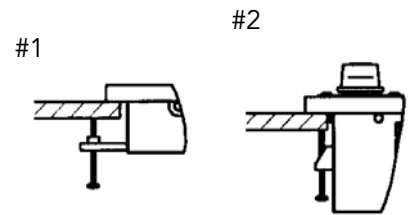

36" W. HEIGHT

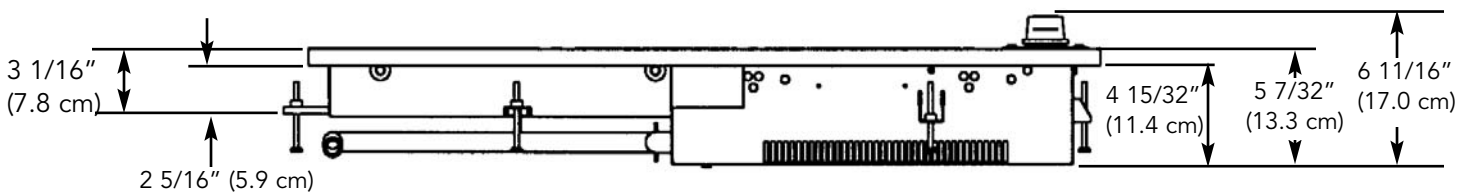

DIMENSIONS ALL INDUCTION COOKTOP

30" W. TOP

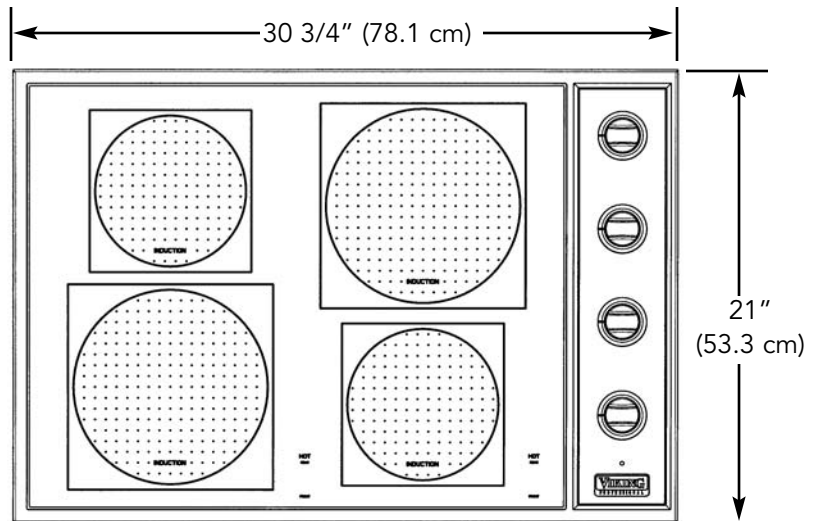

30" W. BURNER BOX

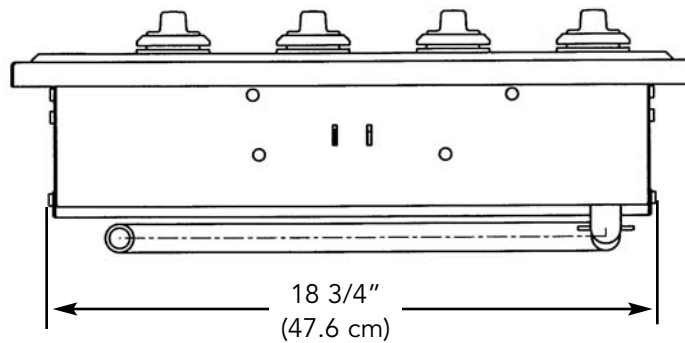

30" W. HEIGHT

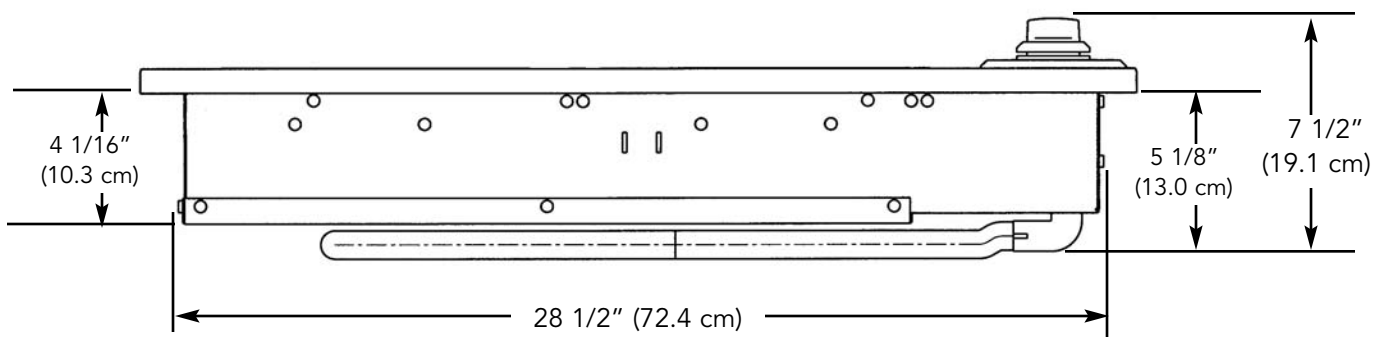

After installation of cooktop, locate the four hold down brackets on each side of the burner box. Screw the sheet metal screw into bracket and tighten firmly against bottom of countertop.

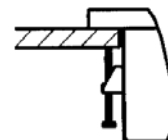

36" W. TOP

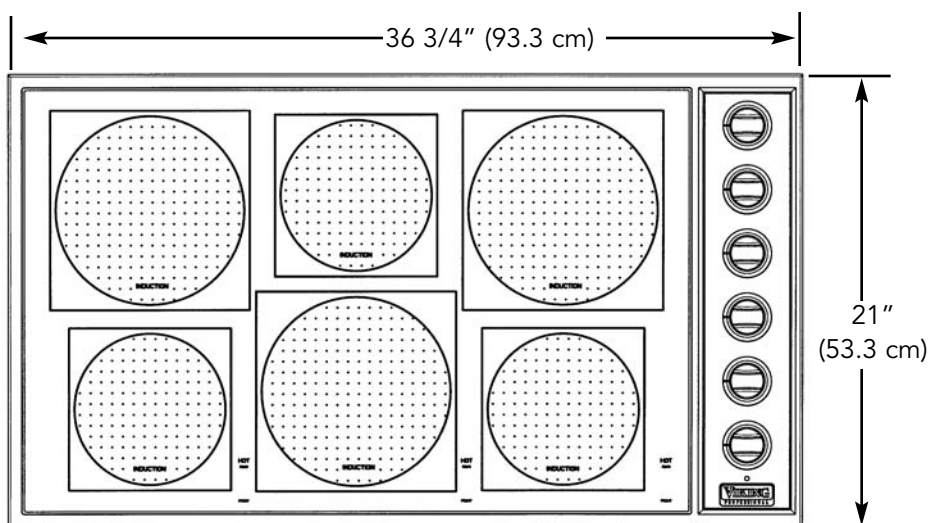

36" W. BURNER BOX

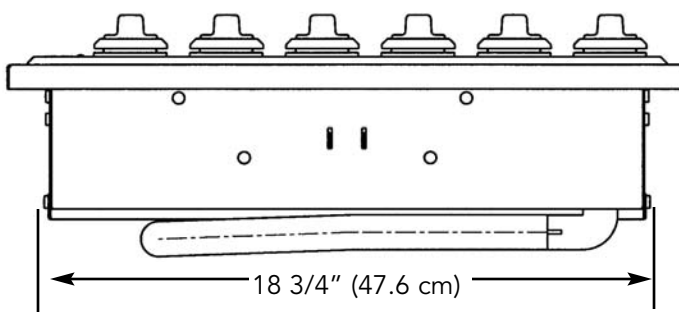

36" W. HEIGHT

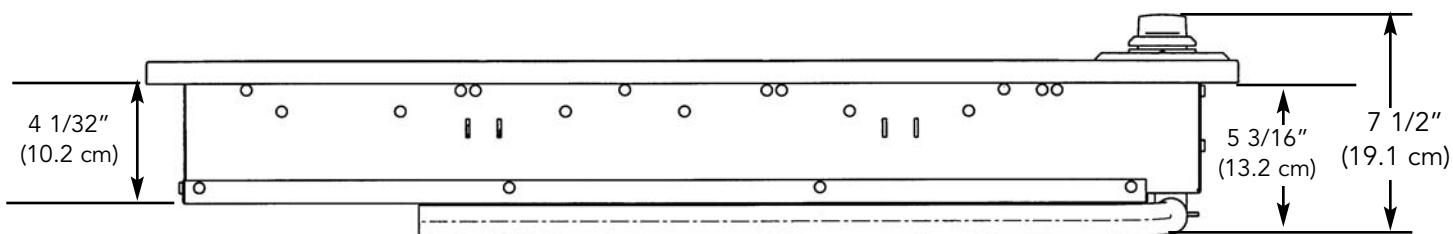

After installation of cooktop, locate the four hold down brackets on each side of the burner box. Screw the sheet metal screw into bracket and tighten firmly against bottom of countertop.

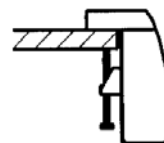

30" W. CUTOUT

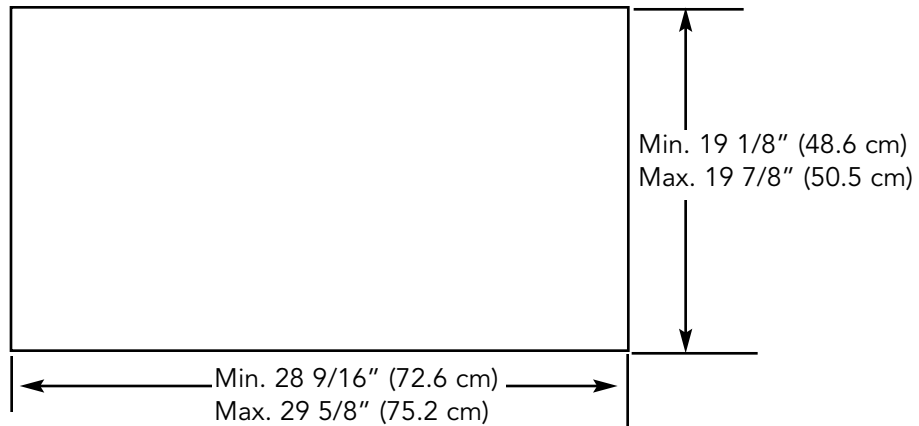

30" W. CUTOUT w/ DOWNDRAFT

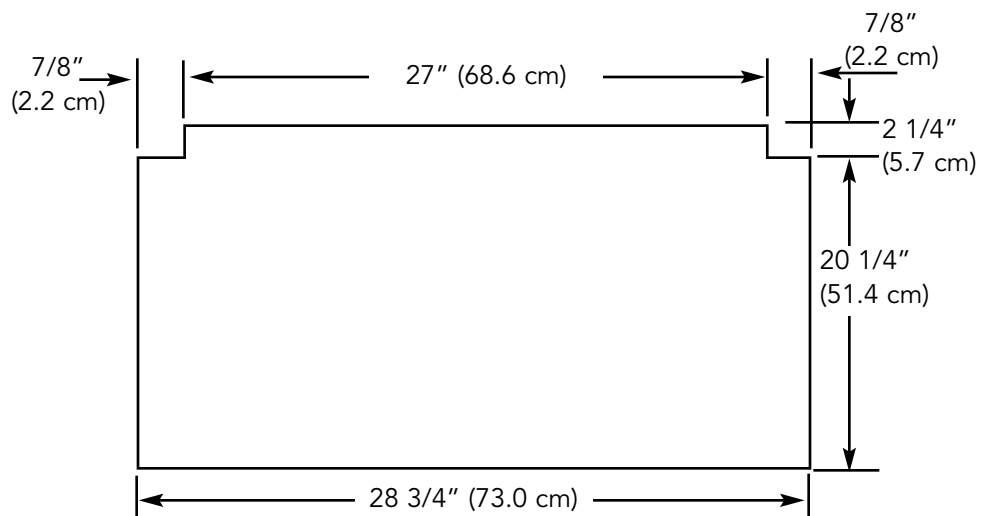

36" W. CUTOUT

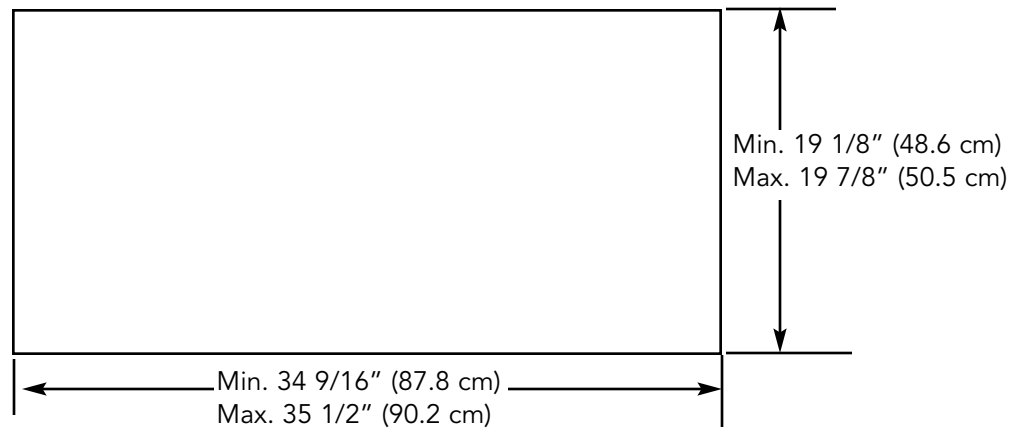

36" W. CUTOUT w/ DOWNDRAFT

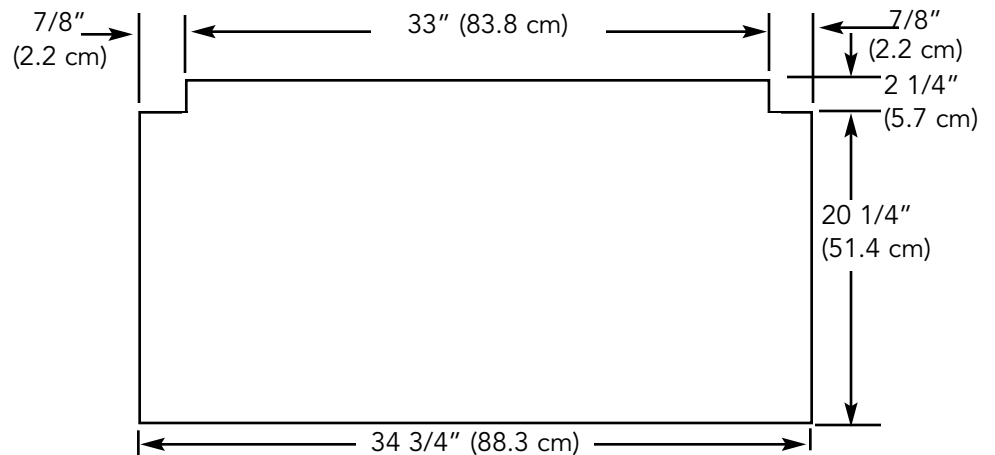

FINAL PREPARATION

1. Some stainless steel parts may have a plastic protective wrap which must be peeled off.
2. All stainless steel body parts should be wiped with hot, soapy water and with a liquid cleaner designed for this material. If buildup occurs, do not use steel wool, abrasive cloths, cleaners, or powders! If it is necessary to scrape stainless steel to remove encrusted materials, soak with hot, wet cloths to loosen the material, then use a wood or nylon scraper. Do not use a metal knife, spatula, or any other metal tool to scrape stainless steel! Scratches are almost impossible to remove.

REPLACEMENT PARTS

Only authorized replacement parts may be used in performing service on the cooktop. Do not repair or replace any part of the appliance unless specifically recommended in the manual. All other servicing should be referred to a qualified technician.

WIRING DIAGRAM 30" W. ALL INDUCTION COOKTOP

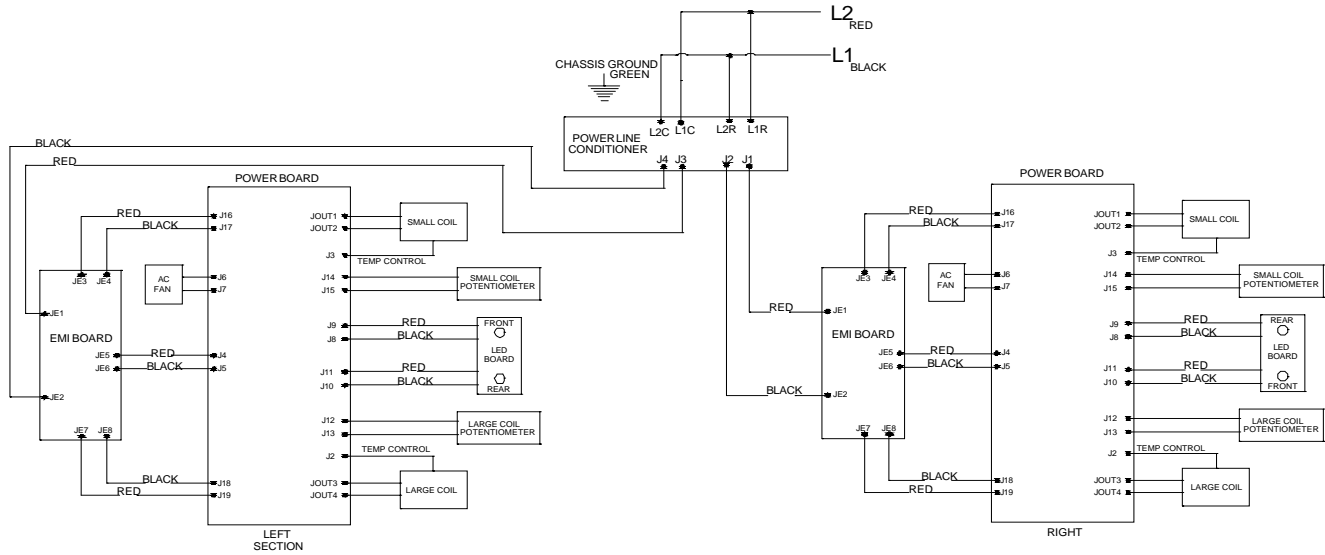

FOR CONNECTION TO FACTORY INSTALLED TERMINAL BLOCK - USE COPPER OR ALUMINUM CONDUCTORS

WARNING- THIS UNIT MUST BE GROUNDED. SEE INSTALLATION INSTRUCTIONS FOR PROPER GROUNDING PROCEDURES

NOTE: TRAILERS OR STRIPES WILL BE THE SECOND COLOR IN A COLOR COMBINATION

WIRING DIAGRAM 36" W. ALL INDUCTION COOKTOP

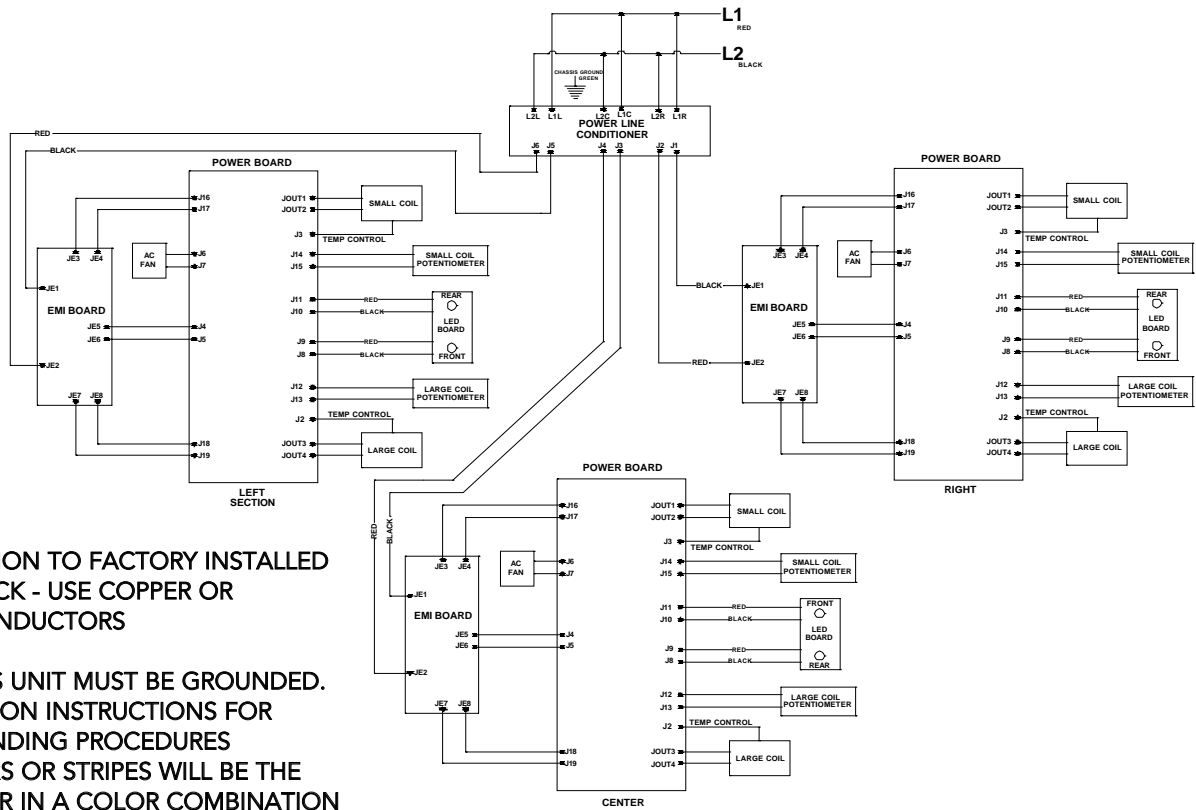

FOR CONNECTION TO FACTORY INSTALLED TERMINAL BLOCK - USE COPPER OR ALUMINUM CONDUCTORS

WARNING- THIS UNIT MUST BE GROUNDED. SEE INSTALLATION INSTRUCTIONS FOR PROPER GROUNDING PROCEDURES

NOTE: TRAILERS OR STRIPES WILL BE THE SECOND COLOR IN A COLOR COMBINATION



Viking Range Corporation
111 Front Street
Greenwood, Mississippi 38930 USA
(662) 455-1200

For more product information
call 1-888-VIKING1 (845-4641)
or visit the Viking Web site at
vikingrange.com