

Setting the Clock

Digital Display (Select Models)

The time-of-day must be set before any other program can be used. When your oven is first connected to the power in your home, the timer display will show --:--. To program the time-of-day:



1. Press the "CLOCK"* button. 12:00 will be displayed with the word SET in the upper right corner.
2. Turn the "Set" knob until the correct time-of-day is displayed. AM and PM are not indicated.
3. Press the "CLOCK" button again. The word SET will disappear and the correct time is now set into the timer.

The time-of-day can be changed by following steps 1 through 3. It cannot be changed while there is a Bake Hours or Start Time cycle programmed into the timer.

Analog Display (Premiere Models)

The time-of-day must be set before any other program can be used. When your oven is first connected to the power in your home, the digital display will show 00:00. To program the time-of-day:

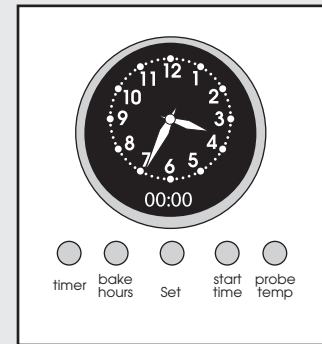

1. Push and hold the "timer" and "bake hours" buttons at the same time.
2. Turn the "Set" knob until correct time is displayed on the digital clock.
3. Release "timer" and "bake hours" buttons.

The analog clock will automatically set after the digital time is set.

Oven Control Panel

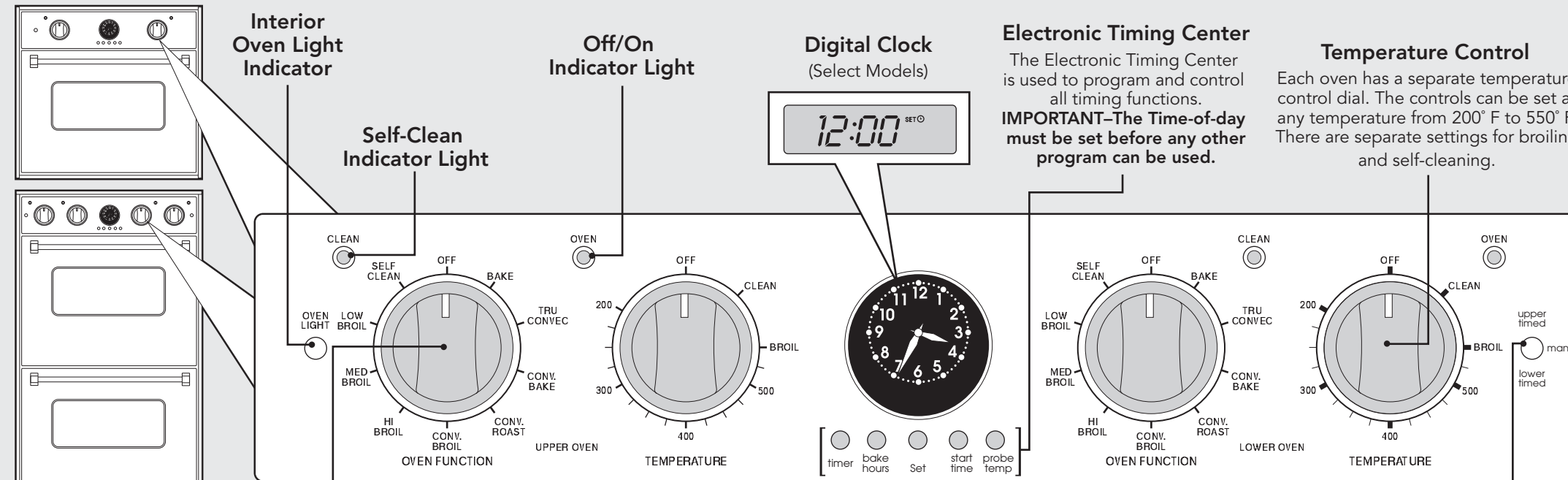

Interior Oven Light Indicator

Off/On Indicator Light

Digital Clock
(Select Models)

Electronic Timing Center

The Electronic Timing Center is used to program and control all timing functions. **IMPORTANT—The Time-of-day must be set before any other program can be used.**

Temperature Control

Each oven has a separate temperature control dial. The controls can be set at any temperature from 200° F to 550° F. There are separate settings for broiling and self-cleaning.

Self-Clean Indicator Light

OVEN FUNCTION

TEMPERATURE

OVEN FUNCTION

TEMPERATURE

OVEN FUNCTION

TEMPERATURE

Manual/Timered Control

Bake
Conventional, single rack baking (breads, cakes, cookies, pastry, pies, entrees, vegetables)

Convection Bake
Multi-rack baking for heavier or frozen foods (e.g., 4 frozen pies, pizzas, entrees, vegetables)

TruConvect™
Multi-rack baking for breads, cakes, cookies (up to 6 racks of cookies at once)

High-Broil
Dark meats at 1" thickness or less where rare or medium doneness is desired

Medium-Broil
White meats such as chicken or meats greater than 1" thick that would be over-browned in high broil

Low-Broil
Delicate broiling such as meringue

Convection Broil
Thicker meats, faster than regular broil & with less smoke generation

Convection Roast
Whole turkeys, whole chickens, hams, etc.

Self-Clean
A pyrolytic self-cleaning cycle where the oven reaches elevated temperatures in order to burn off soils and deposits

Oven Settings and Functions

Temperature Control

Each oven has a separate temperature control dial and a separate oven function selector. The controls can be set at any temperature from 200° F (93.3° C) to 550° F (287.8° C). There are separate settings for broiling and self-cleaning. Always be sure the controls are in the OFF position when the ovens are not in use.

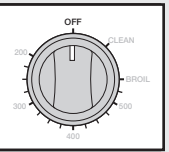

Interior Oven Light Control

The upper and lower ovens have interior oven lights that are controlled by one switch on the control panel. Push the switch to turn the interior oven lights on and off.

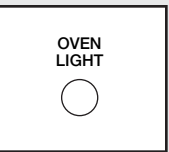

Two-Element Bake

Full power heat is radiated from the bake element in the bottom of the oven cavity and supplemental heat is radiated from the broil element. This function is recommended for single rack baking. Many cookbooks contain recipes to be cooked in the conventional manner. Conventional baking/roasting is particularly suitable for dishes that require a high temperature. Use this setting for baking, roasting, and casseroles.

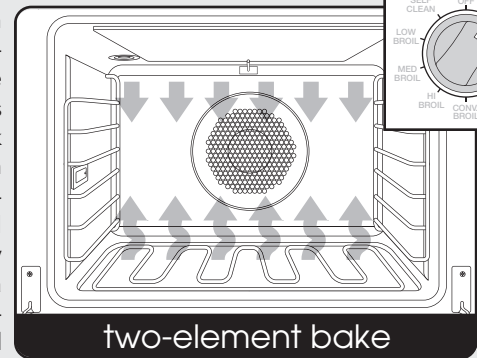

two-element bake

TruConvect™

The rear element only operates at full power. There is no direct heat from the bottom or top elements. The motorized fan in the rear of the oven circulates air in the oven cavity for even heating. Use this setting for foods that require gentle cooking such as pastries, souffles, yeast breads, quick breads and cakes. Breads, cookies, and other baked goods come out evenly textured with golden crusts. No special bakeware is required. Use this function for single rack baking, multiple rack baking, roasting, and preparation of complete meals. This setting is also recommended when baking large quantities of baked goods at one time.

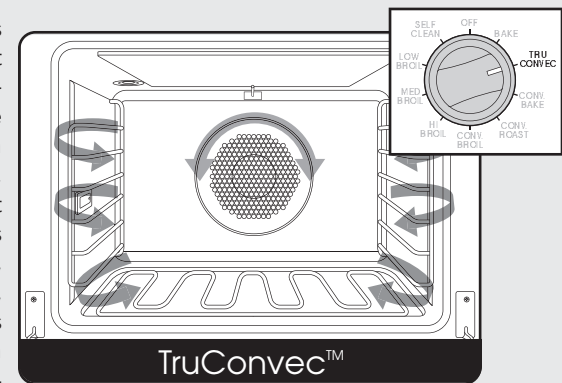

TruConvect™

*Note: The PROBE function is included on the Premiere models

*Note: This is a Professional Premiere Control Panel.

Oven Settings

Convection Bake

The bottom element operates at full power, and the top broil element operates at supplemental power. The heated air is circulated by the motorized fan in the rear of the oven providing a more even heat distribution. This even circulation of air equalizes the temperature throughout the oven cavity and eliminates the hot and cold spots found in conventional ovens. A major benefit of convection baking is the ability to prepare food in quantity using multiple racks – a feature not possible in a standard oven. When roasting, cool air is quickly replaced, searing meats on the outside and retaining more juices and natural flavor on the inside with less shrinkage. With this heating method, foods can be baked and roasted at the same time with minimal taste transfer, even when different dishes are involved, such as cakes, fish or meat. The hot air system is especially economical when thawing frozen food. Use this setting for baking and roasting.

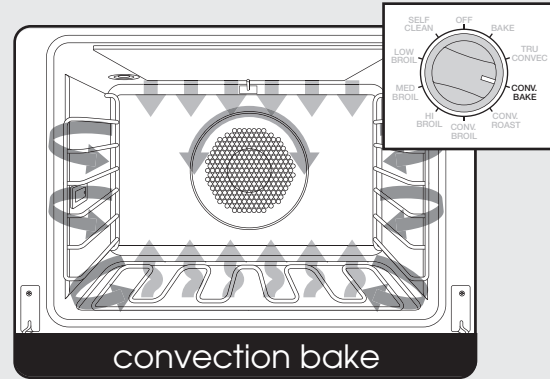

Convection Broil*

The top element operates at full power. This function is exactly the same as regular broiling with the additional benefit of air circulation by the motorized fan in the rear of the oven. Smoke is reduced since the airflow also reduces peak temperatures on the food. Use this setting for broiling thick cuts of meat.

**This function uses a high-speed convection fan for optimum cooking performance. Some noise may be noticed from this high fan speed. This is normal.*

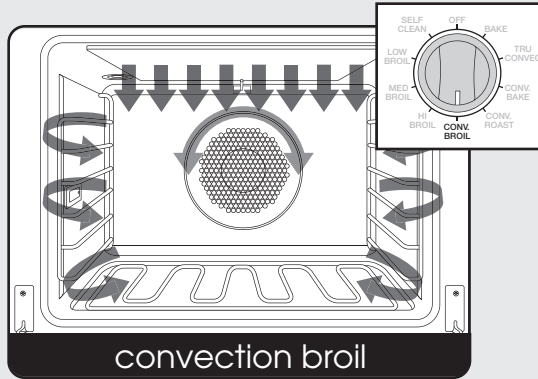

High-Broil

Heat radiates from both broil elements, located in the top of the oven cavity, at full power. The distance between the foods and the broil elements determines broiling speed. For "fast" broiling, food may be as close as 2 inches to the broil element or on the top rack. "Fast" broiling is best for meats where "rare to medium" doneness is desired. Use this setting for broiling small and average cuts of meat.

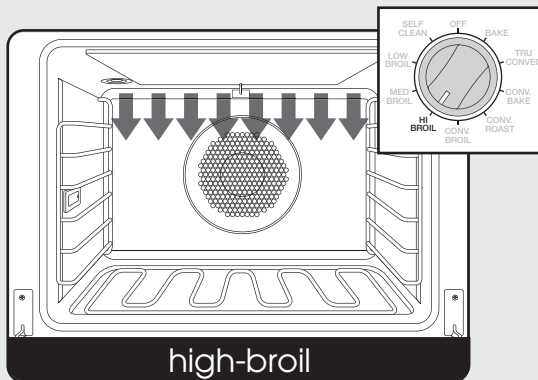

Medium-Broil

Inner and outer broil elements pulse on and off to produce less heat for "slow" broiling. Allow about 4 inches between the top surface of the food and the broil element. "Slow" broiling is best for chicken and ham in order to broil food without over-browning it. Use this setting for broiling small and average cuts of meat.



Convection Roast*

The convection element runs in conjunction with the inner and outer broil elements. The reversible convection fan runs at a higher speed in each direction. This transfer of heat (mainly from the convection element) seals moisture inside of large roasts. A time savings is gained over existing, single fan convection roast modes. Use this setting for whole turkeys, whole chickens, hams, etc.

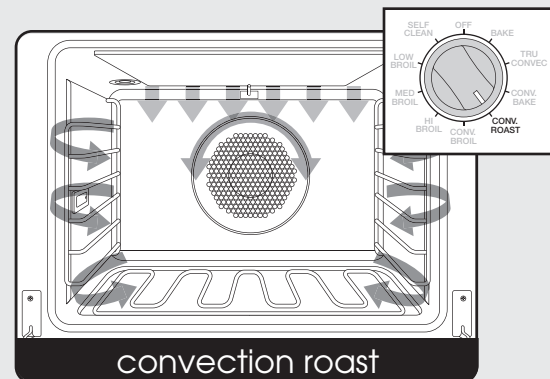

Low-Broil

This mode uses only a fraction of the available power to the inner broil element for delicate top-browning. The inner broil element is on for only part of the time. Use this setting to gently brown meringue on racks 3 or 4 in 3-4 minutes.

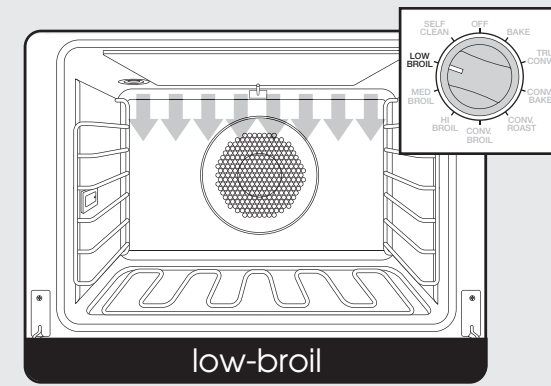

Self-Clean

The pyrolytic self-cleaning cycle is designed to eliminate the need for scrubbing and scouring food baked onto the oven interior. During this cycle, the oven reaches elevated temperatures in order to burn off soils and deposits. An integral smoke eliminator reduces odors associated with the soil burn-off. A powder ash residue is left in the bottom of the oven after completion of the self-clean cycle. When the oven has cooled, remove any ash from oven surfaces with a damp sponge or cloth.

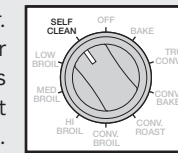

Convection Dehydrate

With the selector set to TruConvec and the temperature control on 150° F (65.6° C), warm air is circulated by a motorized fan in the rear of the oven. Over a period of time, the water is removed from the food by evaporation. Removal of water inhibits growth of microorganisms and retards the activity of enzymes. It is important to remember that dehydration does not improve the quality, so only fresh, top-quality foods should be used.

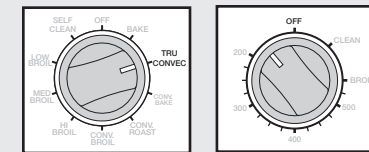

Convection Defrost

With the selector set to convection cook and the temperature control off, air is circulated by a motorized fan in the rear of the oven. The fan accelerates natural defrosting of the food without heat. To avoid sickness and food waste, do not allow defrosted food to remain in the oven for more than two hours.

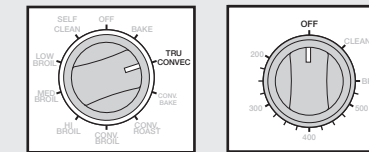

Viking Quick Reference Guide

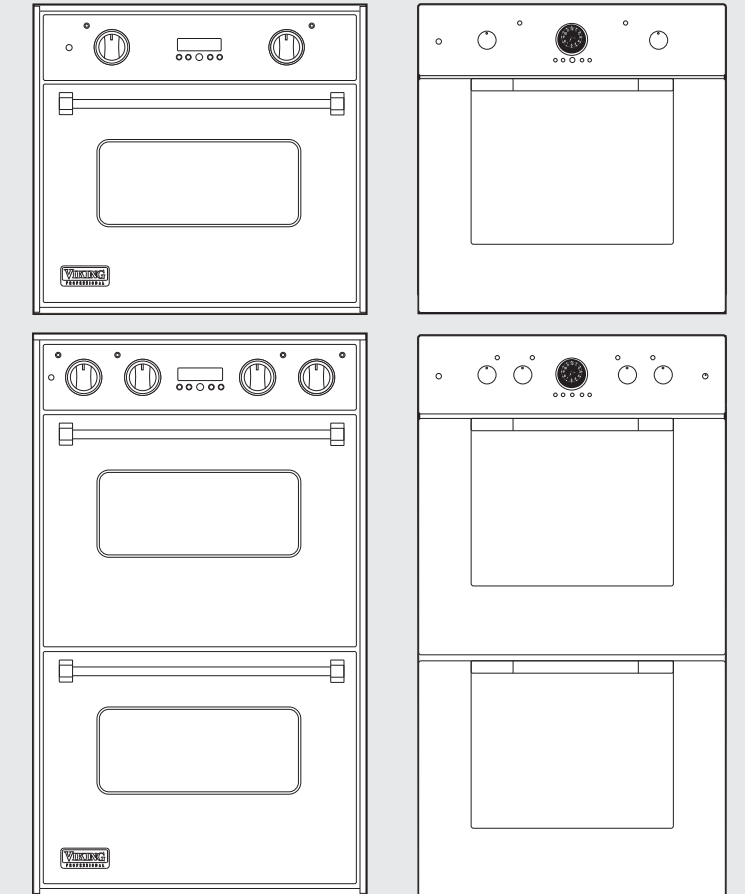

Professional & Designer Series
Built-In Electric Single and Double Ovens

