



Professional Select Built-In Electric 27"/30"W. Single/Double Oven

Standard Features & Accessories

All Professional Select ovens include

- Overall capacity
 - 27"W. models—4.2 cu. ft.
 - 22-5/16"W. x 16-1/2"H. x 19-1/2"D.
 - 30"W. models—4.7 cu. ft.
 - 25-5/16"W. x 16-1/2"H. x 19-1/2"D.
- AHAM* standard capacity (each oven)
 - 27"W. models—3.6 cu. ft.
 - 22-5/16"W. x 16-1/2"H. x 16-13/16"D.
 - 30"W. models—4.1 cu. ft.
 - 25-5/16"W. x 16-1/2"H. x 16-13/16"D.
- **Exclusive**—largest, self-cleaning convection oven(s) available
- **Exclusive**—patent-pending Vari-Speed Dual Flow™ convection system; 8-1/2" diameter two-speed fan (largest in the industry) works bi-directionally for optimal airflow
- **Exclusive**—Rapid Ready™ system provides super-fast preheating
- 10-pass broiler with heat reflector directs heat directly into food for quicker results
- Concealed 10-pass dual bake element makes the oven cavity easy to clean while providing precise temperature control
- Commercial-type styling and performance
 - Heavy-duty handle
 - Large, easy-to-read knobs and bezels
 - Digital clock
 - 100-minute timer
 - Timed Bake feature
 - Set oven to begin cooking up to 24 hours
 - Shuts off when cooking time is complete
- Self-clean setting with indicator light
- High-density insulation contains heat for maximum energy savings, even during high-temperature self-cleaning
- Three heavy-duty, porcelain-coated racks/six rack positions (per oven)
- Includes heavy-duty broiler pan and tray for better broiling performance
- Halogen lighting
- High-performance cooking modes
 - Convection (convection features in top oven only on double ovens)
 - TruConvec™ Convection Cooking (Viking's exclusive air circulation system uses only a convection element in the rear of the oven with fan-forced air—no direct heat from the top or bottom)
 - Convection roast

- Convection bake
- Convection broil
- Convection dehydrate
- Convection defrost
- Conventional
 - Bake
 - Three-level broil
 - High
 - Medium
 - Low

Professional Select Model numbers

- VESO127—27"W. single oven
- VEDO127—27"W. double oven
- VESO130—30"W. single oven
- VEDO130—30"W. double oven

*The AHAM Standard for measuring oven capacity subtracts the door plug and convection baffle dimension from the total oven volume.

Model Options



VESO127/130
Professional Select
Single Oven



VEDO127/130
Professional Select
Double Oven

FINISH DETAILS FOR SELECT MODELS

- Stainless Steel (SS)
 - Finishes designate door front(s). Stainless steel control panel with black knobs/switches.
- Black (BK)
 - Finish designates door front(s). Black control panel and knobs/switches.
- White (WH)
 - Finish designates door front(s). White control panel and knobs/switches.
- Silver finished vertical/horizontal trim and stainless steel handles (with chrome-plated brackets)
- Brass Trim Option (BR)—nameplate, knobs, buttons, window trim, door handle/brackets, and knob bezels. Brass components have a durable protective coating for maintenance-free normal use.

ORDERING INSTRUCTIONS

First specify model number, and then color code (VESO130SS). If ordering optional brass trim, specify code at end (VESO130SSBR).





Professional Premiere Built-In Electric 27"/30"W. Single/Double Oven

Standard Features & Accessories

All Professional Premiere ovens include

- Overall capacity
 - o 27"W. models—4.2 cu. ft.
 - 22-5/16"W. x 16-1/2"H. x 19-1/2"D.
 - o 30"W. models—4.7 cu. ft.
 - 25-5/16"W. x 16-1/2"H. x 19-1/2"D.
- AHAM* standard capacity (each oven)
 - o 27"W. models—3.6 cu. ft.
 - 22-5/16"W. x 16-1/2"H. x 16-13/16"D.
 - o 30"W. models—4.1 cu. ft.
 - 25-5/16"W. x 16-1/2"H. x 16-13/16"D.
- **Exclusive**—largest, self-cleaning convection oven(s) available
- **Exclusive**—patent-pending Vari-Speed Dual Flow™ convection system; 8-1/2" diameter two-speed fan (largest in the industry) works bi-directionally for optimal airflow
- **Exclusive**—Rapid Ready™ system provides super-fast preheating
- Extra-large Gourmet-Glo™ glass enclosed infrared broiler provides superior broiling performance and maximum coverage. Intense heat from this restaurant-quality broiler sears meats and fish, locking in savory juices.
- Concealed 10-pass dual bake element makes the oven cavity easy to clean while providing precise temperature control
- Commercial-type styling and performance
 - o Heavy-duty handle
 - o Large, easy-to-read knobs and bezels
 - o Digital clock
 - 100-minute timer
 - Timed Bake feature
 - o Set oven to begin cooking up to 24 hours
 - o Shuts off when cooking time is complete
 - Self-clean setting with indicator light
 - High-density insulation contains heat for maximum energy savings, even during high-temperature self-cleaning
 - Three heavy-duty, porcelain-coated racks/six rack positions (per oven)
 - Includes heavy-duty broiler pan and tray for better broiling performance
 - Three strategically located oven lights
 - High-performance cooking modes
 - o Convection features in both upper and lower oven of double ovens
 - TruConvec™ Convection Cooking (Viking's exclusive air circulation system uses only a convection element in the rear of the oven with fan-forced air—no direct heat from the top or bottom)
 - Convection roast
 - Convection bake
 - Convection broil
 - Convection dehydrate
 - Convection defrost

- o Conventional
 - Bake
 - Three-level broil
 - o High
 - o Medium
 - o Low
- ProFlow™ Convection Baffle system—engineered to optimize even heat circulation
- Meat probe offers perfect baking/roasting of fine meats (upper oven in double ovens)
 - o Timer sounds and oven shuts off when desired temp is reached
- Includes one TruGlide™ full-extension rack (in each oven cavity), which allows easy access (additional racks available for purchase—see **Installation Notes & Accessories**)

Professional Premiere Model numbers

- VESO527—27"W. single oven
- VEDO527—27"W. double oven
- VESO530—30"W. single oven
- VEDO530—30"W. double oven

*The AHAM Standard for measuring oven capacity subtracts the door plug and convection baffle dimension from the total oven volume.

Model Options



VESO527/530
Professional Premiere
Single Oven



VEDO527/530
Professional Premiere
Double Oven

FINISH DETAILS FOR PREMIERE MODELS

- Stainless Steel (SS), Black (BK), White (WH), Metallic Silver (MS), Graphite Gray (GG), Stone Gray (SG), Taupe (TP), Biscuit (BT), Cotton White (CW), Oyster Gray (OG), Golden Mist (GM), Lemonade (LE), Sage (SA), Mint Julep (MJ), Sea Glass (SE), Iridescent Blue (IB), Viking Blue (VB), Pumpkin (PM), Racing Red (RR), Apple Red (AR), Burgundy (BU), Plum (PL), Chocolate (CH), and Cobalt Blue (CB).

- o Finishes designate door front(s). Stainless steel control panel with black knobs/switches.
- White (WH)
 - o Finish designates door front(s). White control panel and knobs/switches.
- Silver finished vertical/horizontal trim and stainless steel handles (with chrome-plated brackets)

- o Black (BK)
 - o Finish designates door front(s). Black control panel and knobs/switches.
- Brass Trim Option (BR)—nameplate, window trim, door handle(s)/brackets, and knob bezels. Brass components have a durable protective coating for maintenance-free normal use.

ORDERING INSTRUCTIONS

First specify model number, and then color code (VESO527SS). If ordering optional brass trim, specify code at end (VESO527SSBR).





Professional Select & Premiere Built-In Electric 27"/30"W. Single/Double Oven

Dimensions & Specifications

PRODUCT DIMENSIONS & DOOR SWING



VESO127/130
Professional Select
Single Oven

VEDO127/130
Professional Select
Double Oven

VESO5271/5301
Professional Premiere
Single Oven

VEDO5271/5301
Professional Premiere
Double Oven

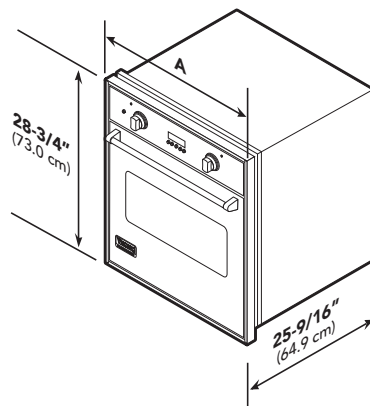

VESO

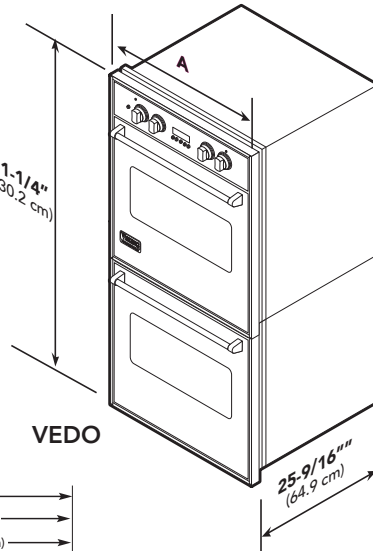

VEDO

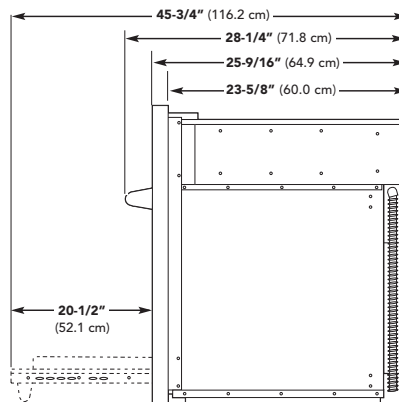

VESO/VEDO

★ Please see **Installation Notes and Accessories** for important installation information, including TruGlide™ Full Extension Oven Racks.



ALL MODELS

Star-K Kosher certification for use on the Jewish Sabbath or Jewish holidays

	VESO127/5271	VEDO127/5271	VESO130/5301	VEDO130/5301
Overall width (A)	26-1/2" (67.3 cm)	26-1/2" (67.3 cm)	29-1/2" (74.9 cm)	29-1/2" (74.9 cm)
Overall height (from bottom)	28-3/4" (73.0 cm)	51-1/4" (130.2 cm)	28-3/4" (73.0 cm)	51-1/4" (130.2 cm)
Overall depth (from rear)				
To edge of door	25-9/16" (64.9 cm)			
With door open	45-3/4" (116.2 cm)			
Interior (each oven)				
Width	22-5/16" (56.7 cm)	22-5/16" (56.7 cm)	25-5/16" (64.3 cm)	25-5/16" (64.3 cm)
Height	16-1/2" (41.9 cm)			
Depth (upper oven)	16-13/16" (42.7 cm)			
Approx. ship weight	258 lbs. (117.6 kg)/ 273 lbs. (123.8 kg)	384 lbs. (174.2 kg)/ 409 lbs. (185.5 kg)	278 lbs. (126.1 kg)/ 293 lbs. (132.9 kg)	424 lbs. (192.3kg)/ 449 lbs. (203.7 kg)





Professional Select & Premiere Built-In Electric 27"/30"W. Single/Double Oven

Installation Requirements

ACCESS REQUIREMENTS

UTILITY REQUIREMENTS

GAS

- Not applicable

ELECTRICAL

- Five-foot flexible steel conduit included. Equipped with No.10 ground wire in unit. Fuse separately.
 - o Four-wire with ground
 - o 240 – 208/120 V/60 Hz
 - o Required electrical connection
 - Singles—30
 - Doubles—50
 - o 50-amp electrical connection for doubles
- Max. amp usage—(240V/208V)
 - o Single—24.0/20.8
 - o Double—40.0/34.7



PLUMBING

Not applicable

VESO127/130
Professional Select
Single Oven

VEDO127/130
Professional Select
Double Oven

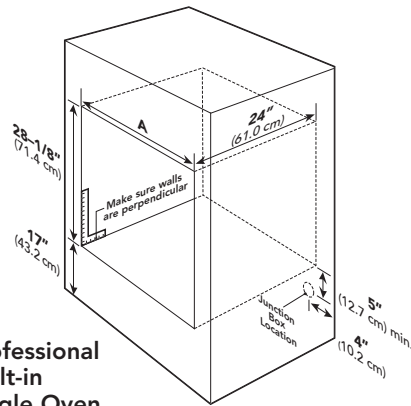
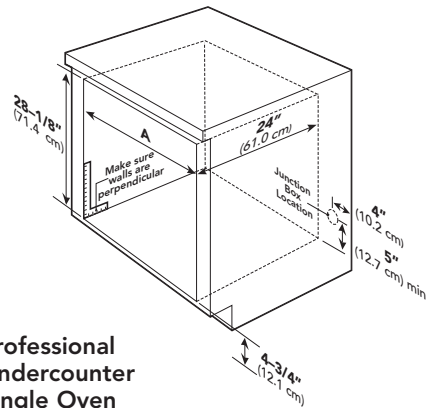
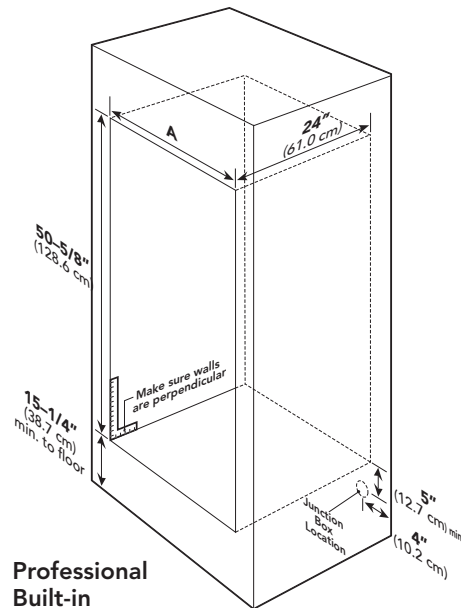
VESO5271/5301
Professional Premiere
Single Oven

VEDO5271/5301
Professional Premiere
Double Oven

Professional Built-in Single Oven

Professional Undercounter Single Oven

Professional Built-in Double Oven

	VESO127/5271	VEDO127/5271	VESO130/5301	VEDO130/5301
Cutout width (A)	25-1/2" (64.8 cm)	25-1/2" (64.8 cm)	28-1/2" (72.4 cm)	28-1/2" (72.4 cm)
Cutout height (from bottom)	28-1/8" (71.4 cm)	50-5/8" (128.6 cm)	28-1/8" (71.4 cm)	50-5/8" (128.6 cm)
Cutout depth	24" (61.0 cm)			



Professional Select & Premiere Built-In Electric 27"/30"W. Single/Double Oven

✦ Installation Notes & Accessories

TruGlide™ Full Extension Oven Racks

- For Professional and Designer Premiere/Select models
- Heavy-duty chrome-plated racks match regular racks shipped with ovens
- Fits securely on rack supports and fully extends, making it easier to load and unload oven
- Can be used in any of the six oven rack positions
- Single rack

Model	Description	Approx. ship wt. lbs. (kg)
TESO27	TruGlide™ rack (27"W.)	13 (5.9)
TESO30	TruGlide™ rack (30"W.)	15 (6.8)

Hearth Stone

- Hard-fired ceramic baking stone
- Absorbs heat and sends it back into food during cooking
- Can be used in all Viking Select and Premiere ovens

Model	Description	Approx. ship wt. lbs. (kg)
OHS18	17-5/8"W. x 13"D. hearth stone	13 (5.9)

V-rack & Drip Pan

- No stick V-rack can be used for cooking roasts, hams, ribs, etc.
- Drip pan catches drippings from items cooked in V-rack to generate flavor and prevent flare-ups

Model	Description	Approx. ship wt. lbs. (kg)
CVD	V-rack and drip pan	4 (1.8)

Broiler Pan & Tray

- For use with all Viking built-in and range ovens
- Heavy-duty porcelainized construction
- Tray allows drippings to fall through to broiler pan
- Tray is removable for easy cleaning

Model	Description	Approx. ship wt. lbs. (kg)
BPT	Broiler pan and tray	5.5 (2.5)

Broiler Pan Rack

- For use with Viking broiler pans
- Provides better broiling and roasting options in convection modes

Model	Description	Approx. ship wt. lbs. (kg)
BPR	Broiler pan rack	1 (0.45)

Compliance Information



WARRANTY INFORMATION*

- One-year full warranty—complete product
- Five-year limited warranty—all oven elements
- Ten-year limited warranty—porcelain oven(s) and porcelain inner door panel
- Ninety-day limited warranty—cosmetic parts such as glass, painted, and decorative items

* For complete warranty see *Use & Care Guide*. Warranty valid on Viking products shipped within the United States and Canada.

