

Factory Parts Catalog

Product No.	E23CS75DSS7
Series	counter depth
Color	stainless
Volts	115
Wiring Diagram	241516401
Owner's Guide	241540102
Market	North America
Energy Guide	240598638
Service Data Sheet	241532603



Electrolux Major Appliances
North & Latin America
P.O. BOX 212378
AUGUSTA, GA 30917

Publication No.
5995436564
05/05/11
(EN/SERVICE/KHB)
357

SIDE-BY-SIDE REFRIGERATOR

Model No.
E23CS75DS

Copyright © 2005 Electrolux Home Products, Inc.
All rights reserved.

FREEZER DOOR

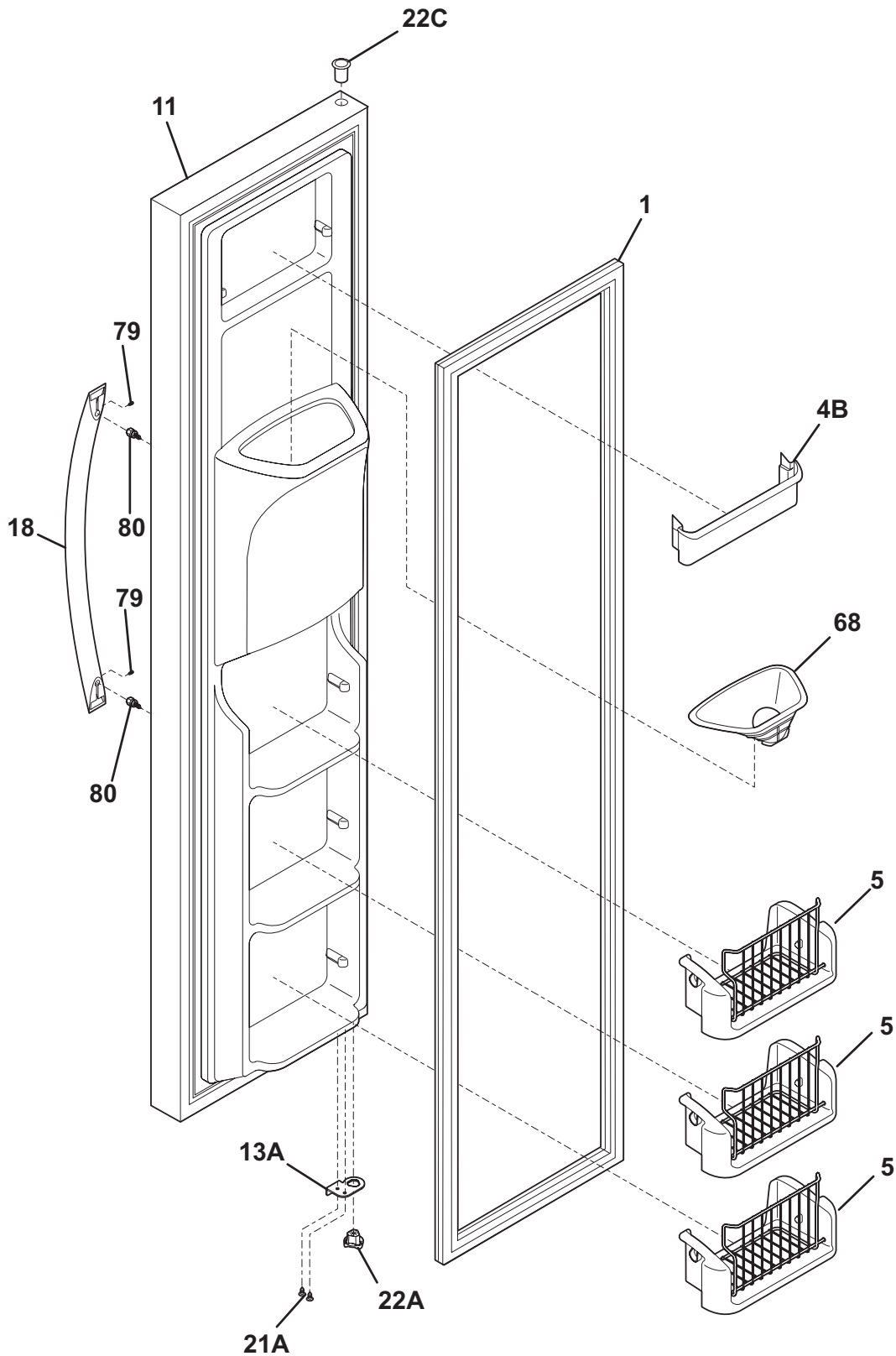

N58FFDEEA0

FREEZER DOOR

POS. NO	PART NO.	DESCRIPTION
1 #	241510202	Gasket-frzr door, white, magnetic
4B	241511604	Bin-door
5	241545001	Bin-tilt out, tilt-out
11	241526703	Door-frzr, stainless steel, complete assy
13A	240581906	Door Stop, black, frzr
18	241531401	Handle-door, stainless steel, with set screw
21A	240598401	Screw, 10-32 x 1/2
22A	240328202	Bearing-hinge(frz), closer
22C	240328404	Bearing-hinge, black, upper
68	241525101	Chute-ice
79	218755402	Screw-set, 10-32 x 0.375
80	241531501	Screw-shoulder, #10 AB, handle mounting
*	240352102	Connector-water, straight
*	240552102	Harness-wiring, door
*	5303918256	Dispenser heater kit

REFRIGERATOR DOOR

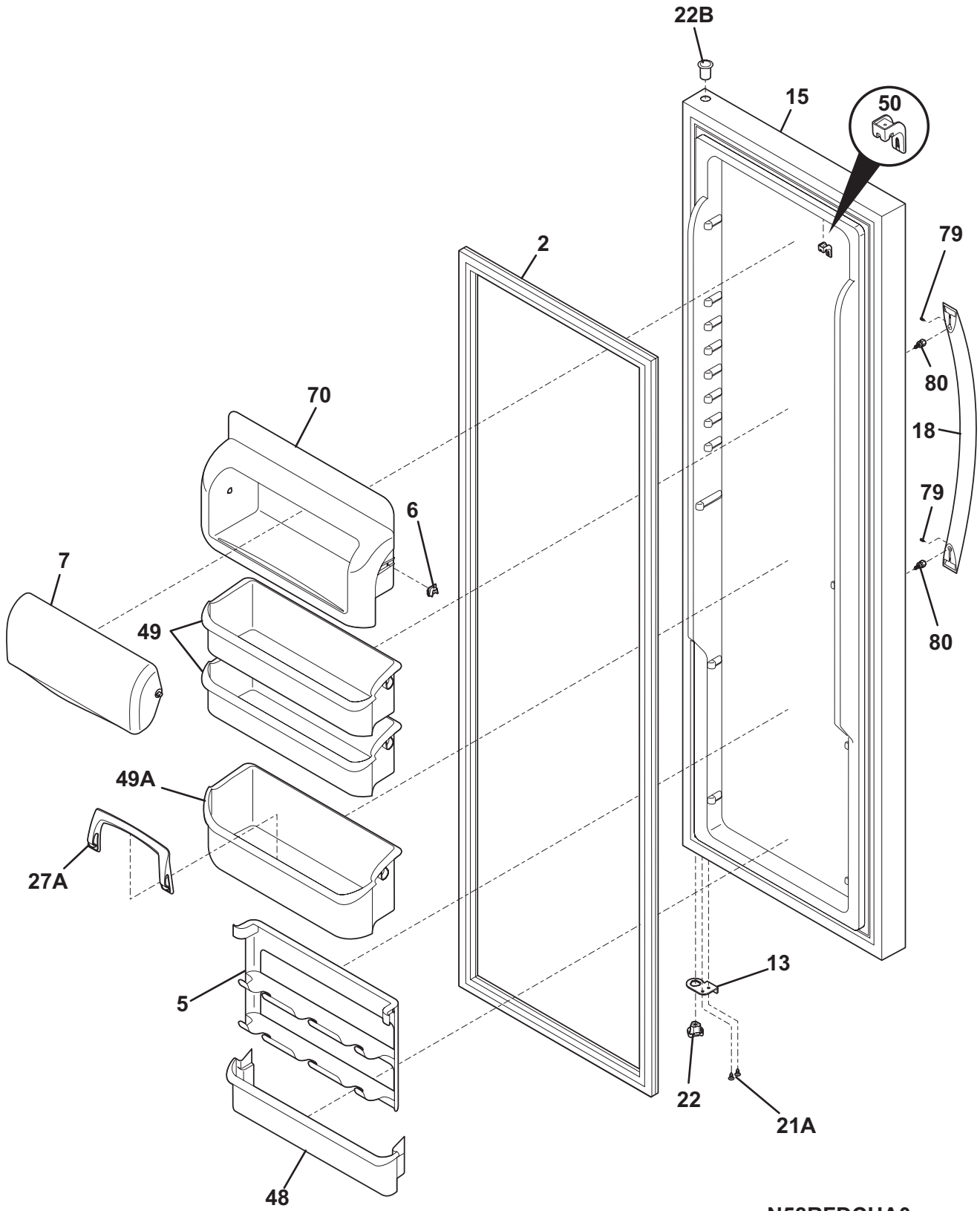

N58RFDCHA0

REFRIGERATOR DOOR

POS. NO	PART NO.	DESCRIPTION
2 #	241510201	Gasket-refr door, white, magnetic
5	241516102	Rack-can
6	241515901	Lug-dairy compartment
7	241515601	Door-dairy
13	240581905	Door Stop, black, ref
15	240345242	Door-refr, stainless steel, complete assy
18	241531401	Handle-door, stainless steel, with set screw
21A	240598401	Screw, 10-32 x 1/2
22	240328201	Bearing-hinge(ref), closer
22B	240328404	Bearing-hinge, black, upper
27A	240396102	Retainer, tall bottle
48	241511705	Bin-door, ref
49	241505505	Bin-door, gallon
49A	241505305	Bin-door, gallon
50	241508401	Cover-magnet
70	241515801	Compartment-dairy, removable
79	218755402	Screw-set, 10-32 x 0.375
80	241531501	Screw-shoulder, #10 AB, handle mounting
*	241530501	Sensor, humidity

CABINET

POS. NO	PART NO.	DESCRIPTION
10	241509802	Cover-air duct
10A	240475908	Cover-evap coil, lower
11	241529301	Plug-hole, factory test
14A	241547901	Switch-light/lamp, frzr door
21C	218252200	Screw, #8 truss hd, 10-32CA x 0.500
22	240457701	Plate-door closer
23	240402701	Screw-#10-32 x 1/4 flat hd
28	240335501	Bolt-roller adj, hex washer head, 1/4-20 x 4.020, (2), special
30	241603701	Bracket-lower hinge, ref
30A	241603702	Bracket-lower hinge
37	240337605	Trim-cabinet corner, silver, (2)
38	240327201	Bracket-upper hinge
40	241551301	Cover-upper hinge, stainless steel
41	241550801	Grommet-shelf mtg, 1.40" long
41*	241550701	Grommet-shelf mtg, .96" long
42	240578901	Screw-hinge mtg, hex head, 1/4-20 x 5/8
43	240335003	Roller Assy, adjustable, front, (2)
45	241500301	Screw, hex washer head, 8-18AB x 0.500
47	241513001	Channel-shelf mtg, side, (2)
50	241511101	Board-main power
50*	241532501	Clip-harness
54	241532401	Channel
58	241595401	Screw-#10-32 X 3/4
66	241513602	Damper-meat keeper
72	241554701	Grille/Kickplate
73	241548001	Screw, 10-32 x 1/2
81	5308016566	Screw, hex washer head, 8-15A x 0.625, low profile
82	5304418225	Roller, compressor base, rear, (2)
83	5303316859	Rivet, flat head, 1/4 OD x 1-3/4, roller pin
89	241574602	Cover access
90	218249808	Seal-coil cover
92	216850900	Screw, hex washer hd, 1/4 x 7/8, hinge mtg
100	240423701	Support, crisper cover, front, (4)
100*	240350802	Support, crisper cover, rear, (4)
*	240396801	Clamp, tube/wiring, nylon, black/natural
*	240479601	Plug, button, cab liner holes, (2)
*	241581801	Paint-pen
*	241591701	Louver

SHELVES

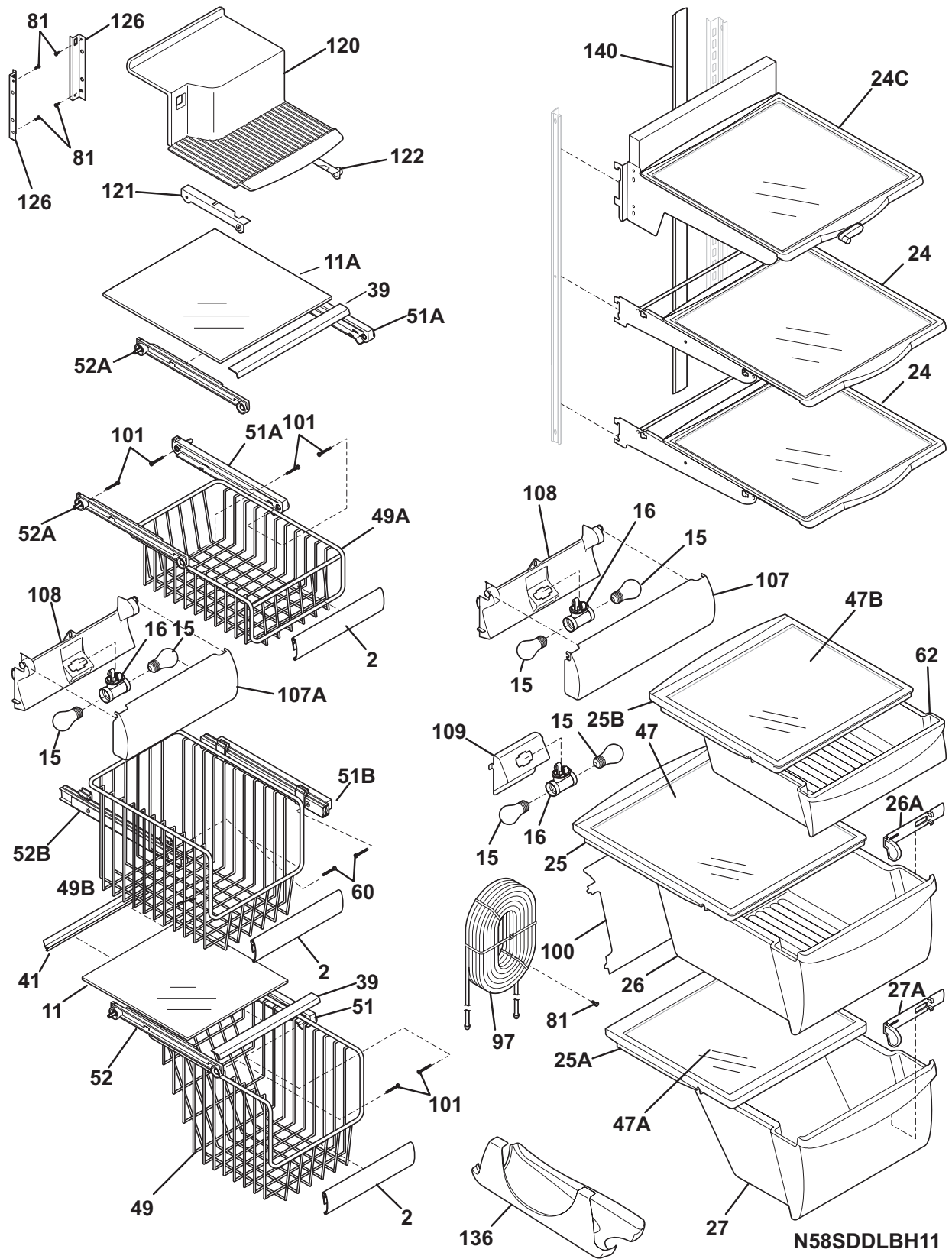

SHELVES

POS. NO	PART NO.	DESCRIPTION
2	241539501	Trim-basket
11	240443357	Shelf-freezer, glass, lower
11A	240443358	Shelf-freezer, glass, upper
15	241552801	Light Bulb
16	241507803	Socket-light
16*	241510801	Harness-wiring
16*	241513101	Harness-wiring
24	240350127	Shelf-"Spill-Safe", cantilever, sliding
24C	240424606	Shelf-"Spill-Safe", sliding, "Aspect", complete
25	240599301	Cover-crisper pan, upper
25*	240362101	Clip-slide, cover-crisper
25A	240350902	Cover-crisper pan, lower
25B	240443356	Shelf-deli pan cover
26	240351027	Pan-crisper, upper
26*	240349801	Clip-slide, pan-crisper
26*	240423101	Channel-divider
26*	240423201	Retainer
26*	240423305	Divider-crisper pan
26A	241638201	Control-humidity
26A*	241638101	Frame-humidity control
27	240351223	Pan-crisper, lower
27A	240362201	Control-humidity
39	240367603	Trim-shelf, 11.65", front
41	241571201	Trim-shelf, rear
47	240350649	Insert-pan cover, glass
47A	240350603	Insert-pan cover, glass
47B	240599801	Cover-meat pan
49	241541801	Basket-sliding
49A	241541901	Basket-sliding, upper, half
49B	241541701	Basket-sliding, upper, full
51	241514501	Hanger-basket, RH
51A	241514701	Hanger-shelf glass, RH
51B	240579803	Hanger-basket, RH
52	241514601	Hanger-basket, LH
52A	241514801	Hanger-shelf glass, LH
52B	240579804	Hanger-basket, LH
60	218362500	Screw, hex washer head, 8-18AB x 1.250, spacer, (2)
62	240599702	Pan-meat
81	5308016566	Screw, hex washer head, 8-15A x 0.625, low profile
97	241532002	Water Tank
100	241549901	Cover-water tank
101	218493100	Screw, hex washer head, 8-18AB x 1-3/4
107	241513401	Shield-light, crisper
107A	241521801	Shield-light, frzr
108	241513301	Cover-wiring, crisper light
109	241513202	Base-crisper light socket
120	241504501	Shelf-ice cream
121	241504701	Rail-ice cream shelf, LH
122	241504702	Rail-ice cream shelf, RH
126	241630701	Channel, auger mtg, LH
126	241630702	Channel, auger mtg, RH
136	240424502	Dispenser-can, clear
140	240430505	Channel, wtr tube cover

CONTROLS

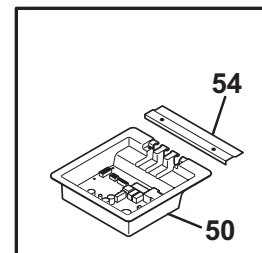
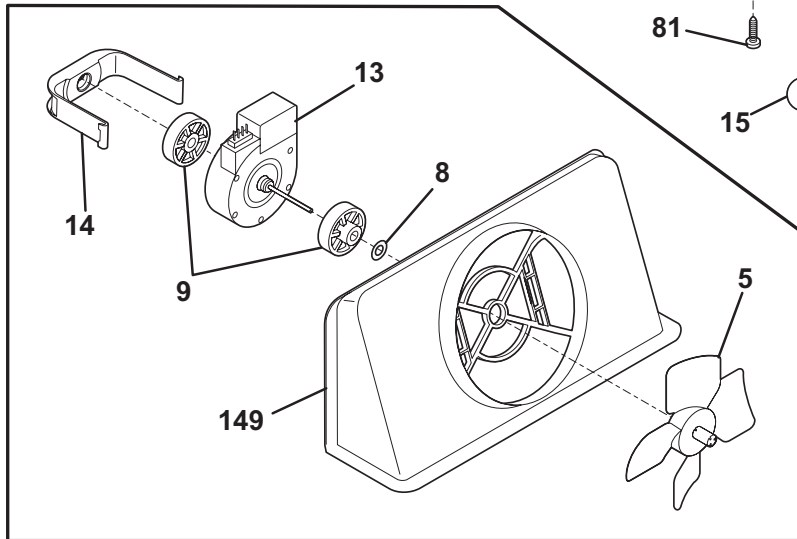
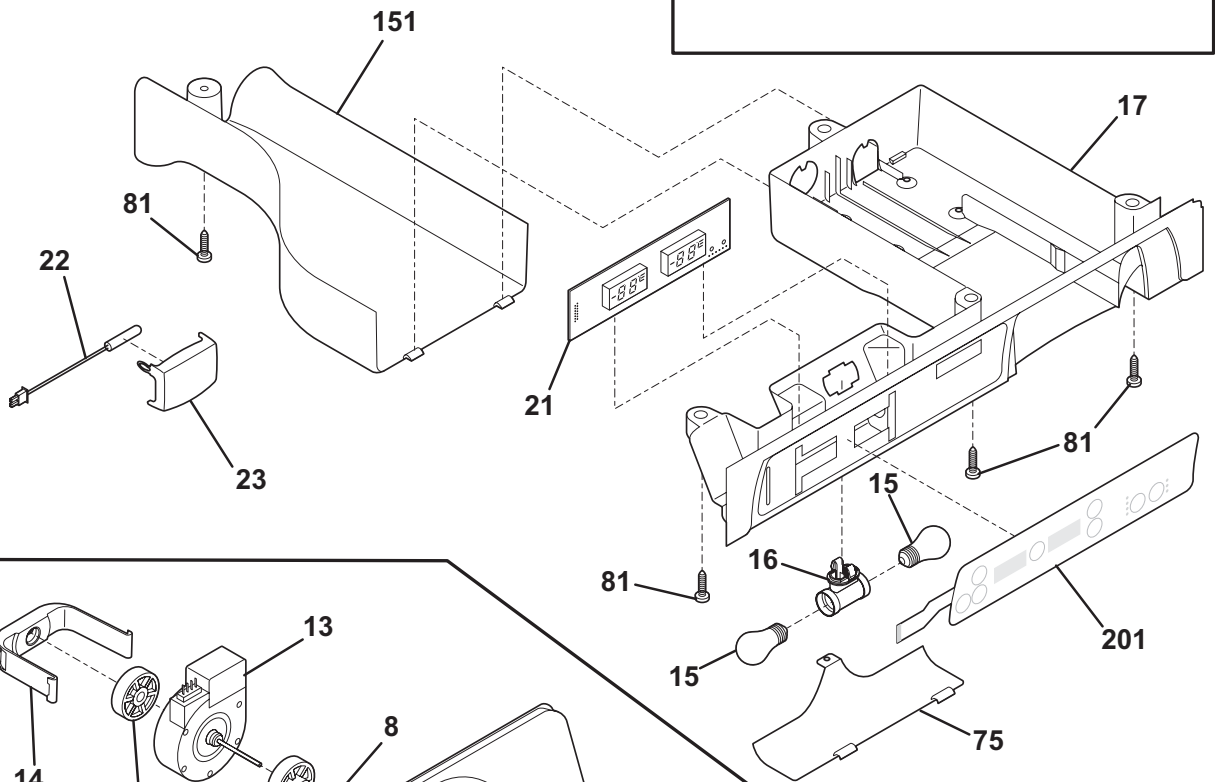
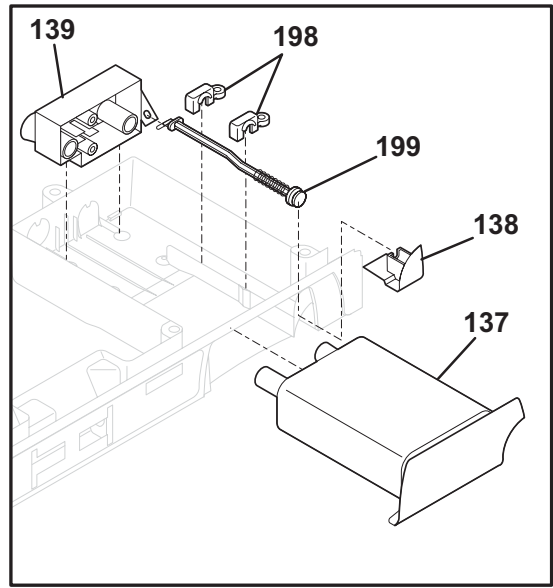
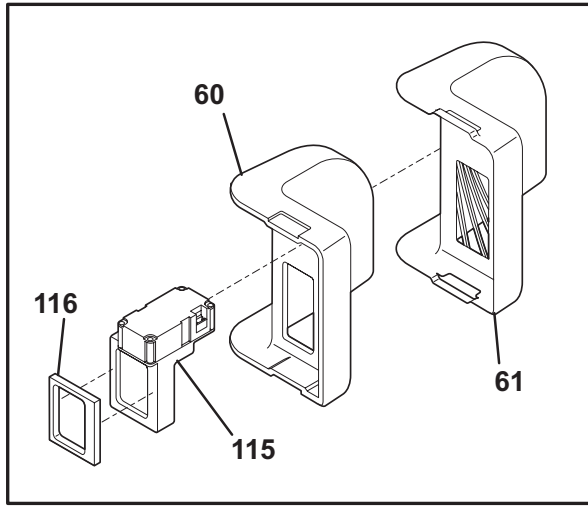

N58TBAAAB2

CONTROLS

POS. NO	PART NO.	DESCRIPTION
5 #	5308000010	Fan Blade, red, evaporator fan
8	215474201	Washer, "slinger", nylon, evap fan shaft
9	241518301	Bushing, motor mounting
13	241509401	Motor, evaporator fan
13*	241510501	Seal-diffuser
14	241517701	Clip, evap fan motor
15	241552801	Light Bulb
16	241507803	Socket-light
16*	241510801	Harness-wiring
17	241516201	Box-control, front
21#	241528201	Control-temperature
22	240597201	Sensor
23	241512901	Cover-sensor
50	241511101	Board-main power
50*	241524801	Seal-Mother Board Housing
54	241532401	Channel
60	241510401	Diffuser-air, top
61	241511201	Cover
75	241517801	Shield-light
81	5308016566	Screw, hex washer head, 8-15A x 0.625, low profile
115	241518501	Damper, motorized
116	241518601	Seal-damper, foam
137#	240396405	Filter, water, carbon cassette, front, with o'rings
137*	240396701	Bypass, water filter, Optional Part
138	240397301	Button-filter release
139	240396001	Base-water filter
139*	240526901	O-ring, wtr filter base
149	241517601	Shroud-evap fan mtg
149*	241528301	Seal, foam, evap fan assy
151	241505001	Cover-water tube
198	240397401	Retainer
199	240397501	Rod
199*	240398401	Spring-filter release rod
201	241544901	Switch-membrane
*	3205266	Edge Protector, wiring harness

SYSTEM

POS. NO	PART NO.	DESCRIPTION
1	240333603	Condenser
3	218679607	Block-evap coil, styrofoam, (2)
4 #	218944001	Drier-filter, R134a System
6 #	241516901	Cord-service
6*	241510801	Harness-wiring
6*	241520401	Harness-wiring
6*	241635601	Harness-wiring, machine compt
14 #	240316107	Heater-defrost
15 #	5303918284	Evaporator Kit
16	5308000110	Strap-evap/heater, aluminum, (2)
21	5303918214	Thermostat-defrost, kit
22	240330008	Base-compressor mtg
22*	218252200	Screw, #8 truss hd, 10-32CA x 0.500
23	218513300	Grommet-compr mtg, (4)
25	240491501	Screw-compressor mtg, 1/4-28 x 1.16, shoulder, typ CF
26	241637301	Pan-defrost drain
29	5303918314	Compressor, w/o electricals
30	241527803	Starter-TSD
32	241527901	Clamp, elec cont mtg, compressor
34	240405201	Grommet, rubber, black, cond tube/wire
41	240555001	Screw-#8-32 X 3/8
44	215174700	Clamp-service cord, strain relief, galv steel
45	5308016566	Screw, hex washer head, 8-15A x 0.625, low profile
55	218909915	Capacitor-run, 220 VAC, 15 microfarad
57	240542601	Clip-wiring harness
58	240433201	Screw, hex washer head, 8-18 x 0.375
59	240315502	Shroud-cond fan
59*	240346701	Tape-foam seal, shroud
59*	240359401	Screw-fan shroud, (2)
59A	240346501	Bracket-support, cond mtr, (3)
59B	240346601	Grommet-bracket, (3)
60 #	241584301	Motor-condenser fan
61	241639501	Blade-condenser fan
62	240429402	Trough-drain
70	218990801	Bracket-evap/cvr mtg
82	5304418225	Roller, compressor base, rear, (2)
83	5303316859	Rivet, flat head, 1/4 OD x 1-3/4, roller pin
84	5304421068	Tube-drain, lower
85	240553501	Tube-connector, suction
86	240409302	Spacer-cond tube, black
* #	5303918300	Heat Exchanger Kit, suction line
*	5303918222	Hot Tube Repair Kit, service

ICE & WATER DISPENSER

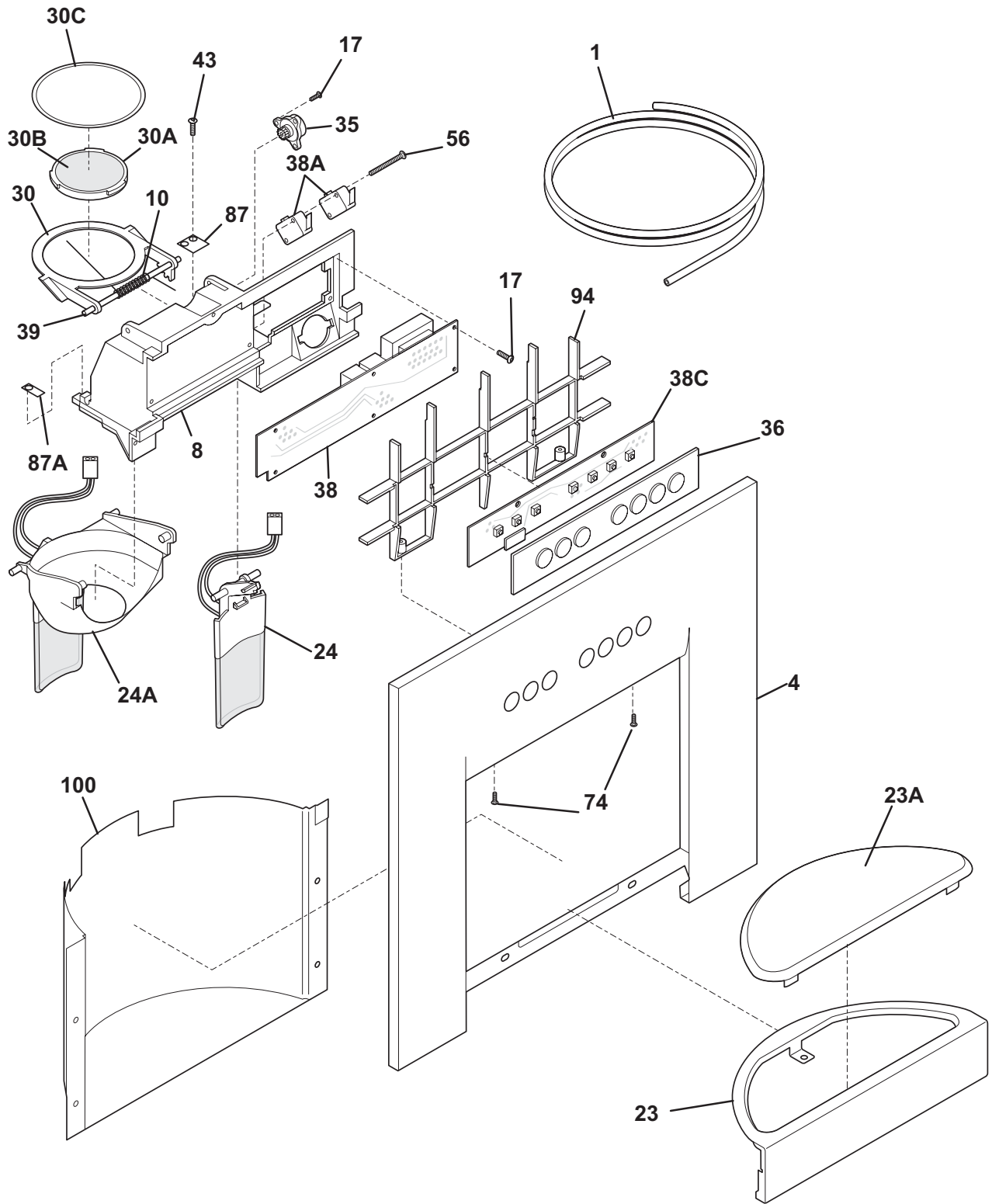

N58XECAA0

ICE & WATER DISPENSER

POS. NO	PART NO.	DESCRIPTION
1	218976409	Tube-water-DOOR
1*	218976901	Tube-water inlet, inlet valve, to ice maker
1*	218976903	Tube-water inlet, inlet valve, to filter
1*	218976912	Tube-water inlet, valve to door
1*	240561701	Seal-water inlet, inlet valve, to ice maker
4	241533203	Cover-module, stainless
4*	241533401	Seal, foam
8	5304430838	Module-dispenser, gray
10	5304426649	Spring-torsion
17	5304421619	Screw
23	241531101	Drip Tray, stainless
23A	241531601	Drip Tray Insert
24	5304442816	Actuator-water, gray
24A	5304442815	Actuator-ice, gray
30	5304421628	Door Assy-ice chute
30A	5304421624	Door center
30B	5304421625	Insulation-door
30C	5304421629	Door seal
35	5304421620	Damper-rotary
36	241533501	Button Module, stainless
38	241527601	Board-power
38A#	5304421617	Switch-micro, single pole, double throw
38C	241527501	Board-control
38C*	5304430811	Harness-ribbon cable
39	5304421627	Pin-hinge
43	215296300	Screw, plask h/l, #6 x 3/8
56	5304421830	Screw-micro switch, pan head
74	5304436349	Screw
87	5304421622	Bearing Plate
87A	5304421621	Bearing Plate
94	241533301	Support, control board
100	241530401	Liner, dispen housing, stainless
*	5304426535	Insulator-electrical
*	241510902	Harness-dispenser
*	5303918256	Dispenser heater kit

ICE CONTAINER

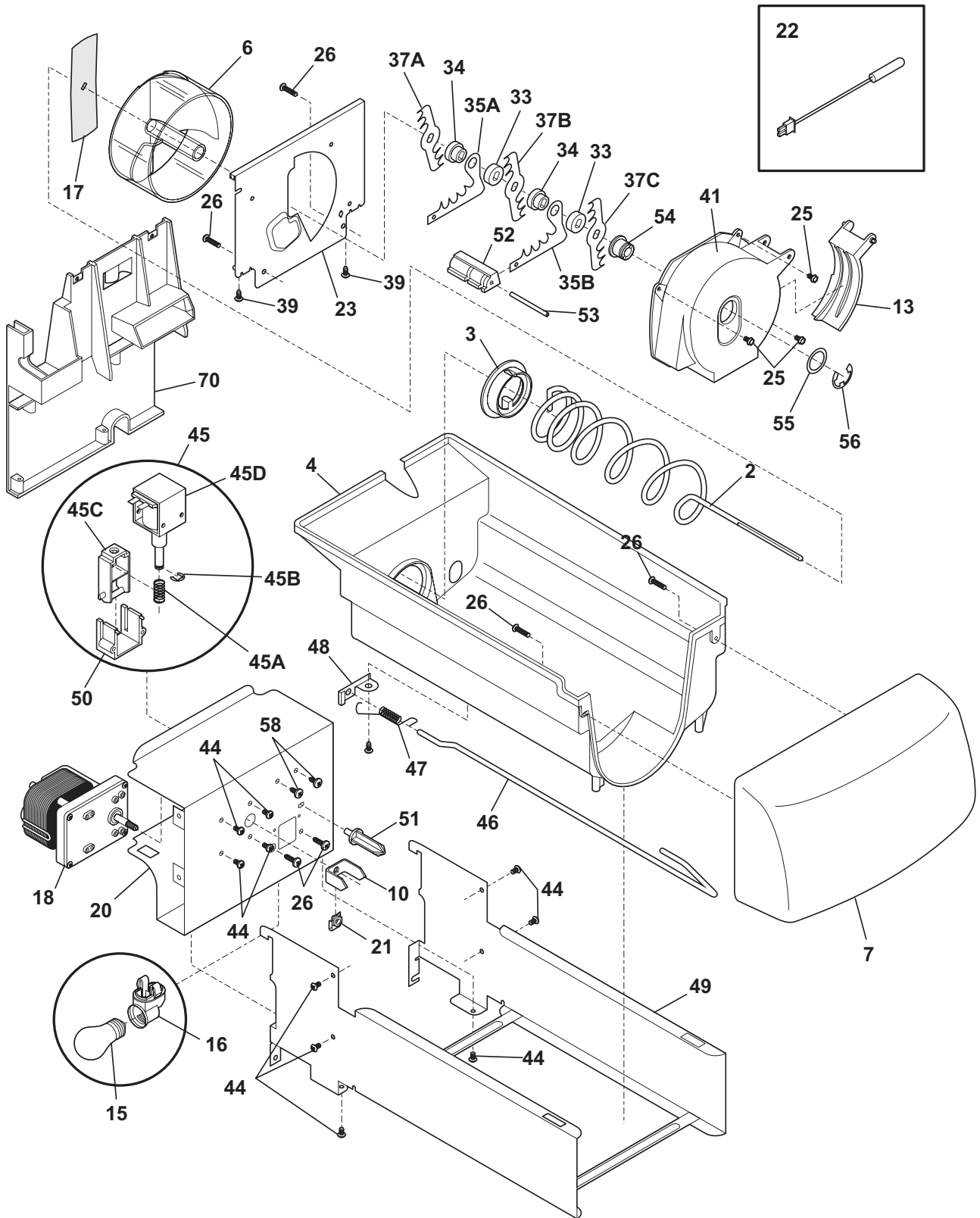

N58YDAAAC0

ICE CONTAINER

POS. NO	PART NO.	DESCRIPTION
2	5304436634	Auger-ice
3	5304404343	Cam-drive
4	241515201	Container-ice, bucket only
6	5304404346	Drum-ice disp
7	241515301	Front-ice container
10	241624801	Bar-drive
13	5304404359	Gate
15	241555401	Light Bulb
16	241559801	Socket-light
17	5304404345	Drive Blade
18 #	5304440392	Motor-auger
18*	241522901	Harness-wiring, icmkr/container
18*#	240352601	Wiring Harness, internal, with plug
20	5304404332	Cover-motor
21	215285100	Nut-drive
22	240597201	Sensor
22*	241519401	Clip, sensor
23	5304404347	Plate-front
25	5304404362	Screw, hex washer head, 8-32T x 0.375
26	215503200	Screw, cr pan hd, 10-16 x 0.500
33	5304404351	Spacer
34	5304404349	Spacer
35A	5304404353	Fixed Blade, round
35B	5304404352	Fixed Blade, square
37A	5304404348	Blade, crusher #1
37B	5304404350	Blade, crusher #2
37C	5304404356	Blade, crusher #3
39	5304404365	Screw
41	5304404358	Housing-crusher
44	218359200	Screw, pan head, 8-32 x 0.250
45 #	5304404333	Solenoid Assy
45A	5304406816	Spring-solenoid
45B	5304406817	E-Ring-solenoid
45C	5304406818	Actuator-solenoid
45D	5304406819	Solenoid
46	5304436635	Control Rod
47	5304404342	Spring-control rod
48	5304404340	Bracket-control rod
48*	5304404364	Screw-bracket
49	5304436702	Rail Assy
50	5304404334	Guide-solenoid
51	5304404336	Rotation Stop
52	5304404354	Spacer-fixed blades
53	5304404355	Pin-spiral, fixed blades
54	5304404357	Nut-auger
55	5304404360	Washer
56	5304404361	E-ring
58	5304404331	Screw-solenoid
70	241504601	Plate-mounting
*	241551601	Screw, hex head, 8-18B x 0.875
*	240562101	Insulator
*	241504301	Ice Container Assy, w/moving parts

ICE MAKER

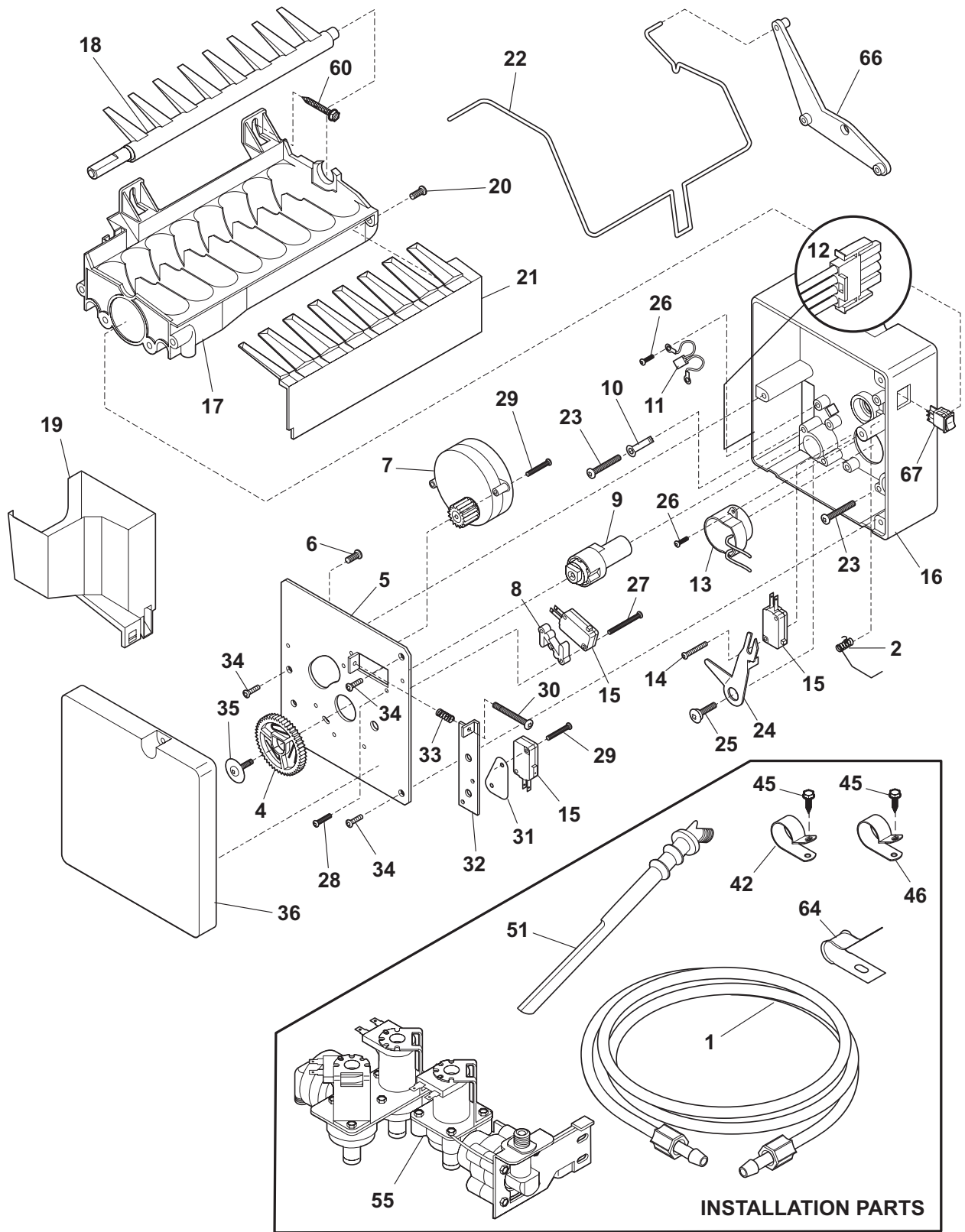

N58I115T

ICE MAKER

POS. NO	PART NO.	DESCRIPTION
1	218976409	Tube-water-DOOR
1*	218976901	Tube-water inlet, inlet valve, to ice maker
1*	218976903	Tube-water inlet, inlet valve, to filter
1*	218976912	Tube-water inlet, valve to door
1*	240561701	Seal-water inlet, inlet valve, to ice maker
1*	241604801	Seal-water inlet, inlet valve, to ice maker
2	5304436616	Spring, torsion
4	3206301	Gear
5	5304436604	Plate-mounting
6	3206305	Screw-ground wire, 8-32 x 0.250
7 #	5304436619	Motor-ice maker
8	3206312	Spacer-hold switch
9	5304436610	Detent
10	3206315	Clamp
11 #	5304436618	Thermal Cutoff, ICE MAKER, complete assy
12	5304436614	Harness-wiring
13	5304436613	Thermostat, ICE MAKER
14	5304420652	Screw, 4 x 0.750, switch mtg.
15 #	3206324	Switch, (3)
16	5304436609	Housing, control
17 #	5304436617	Mold-ice maker, with heater
18	5304436607	Ejector-ice
18*#	240352601	Wiring Harness, internal, with plug
19	5304436606	Cup-water inlet
20	5304408581	Screw, 8-32 x 0.375
21	5304436608	Ice Stripper
22	5304436602	Shut-off Arm
23	5304408582	Screw, 8-32 x 0.875, mold-to-support, (3)
24	3206335	Lever Arm
25	5304404362	Screw, hex washer head, 8-32T x 0.375
26	5304420654	Screw-thermo/sprt, 4-24 x 0.375, (4)
27	3206338	Screw, 4-40 x 1.000, hold switch mtg, (2)
28	3206339	Screw-timing stop, 4-40 x 0.375
29	3206323	Screw, 4-24 x 0.750, (6)
30	3206341	Screw-timing adj, 8-32 x 1.000
31	3206342	Insulator
32	3206343	Plate-valve switch
33	5304436615	Spring-thermostat
34	5304420655	Screw, plazscrew, 8-10, (3)
35	5304408585	Screw
36	5304436605	Cover-ice maker
42	5303001199	Clamp-wiring harness, strain relief, galv steel
42*	218515402	Clip, (2), tube mtg.
45	5308016566	Screw, hex washer head, 8-15A x 0.625, low profile
46	5303001193	Clamp, .50 ID, steel, water tube
51	241523502	Tube-water fill, extension
55 #	240531101	Valve-water, triple solenoid
55*	218709100	Screw, hex head, 10-32 x 0.500
55*	240363601	Screw-shoulder
55*	240542901	Cap-water valve
60	5303207328	Screw, hex washer head, 8-15A x 1.000, (2)
64	5303001549	Clamp, 0.31 ID, steel, copper wtr line
66	5304436611	Bracket-ice maker
67	5304436612	Switch, on/off
*	218888001	Adapter-water supply, nut & sleeve, compression ftg
*	241583301	Deflector-air, ICE MAKER
*	241627701	Ice Maker, Radius Cube, 115 V, no instl parts

WIRING SCHEMATIC

