

Miele

Operating and Installation Instructions

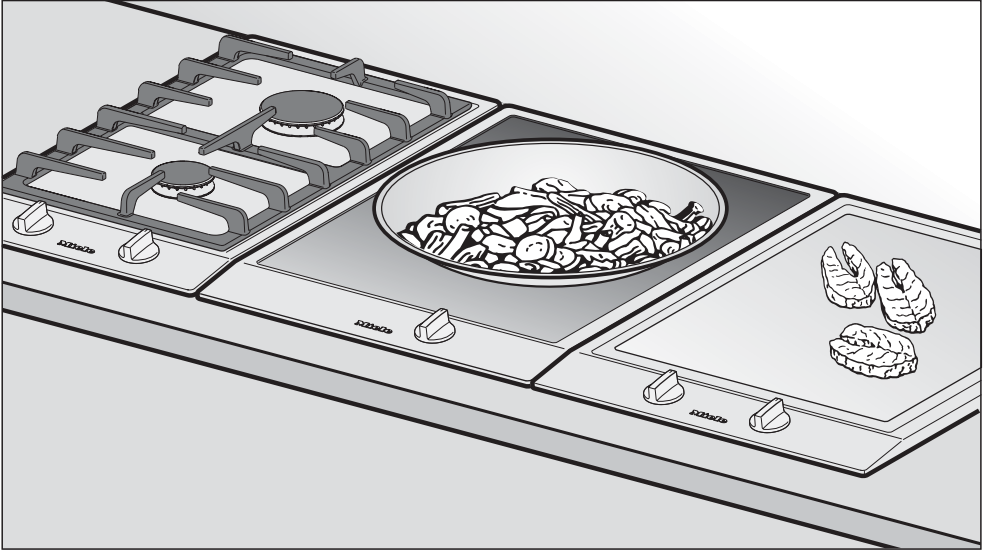

Gas Combiset CS 1012



To prevent accidents and
machine damage,
read the Operating Manual
before
installation or use.

en - US, CA

M.-Nr. 07 366 180

WARNING:

If the information in this manual is not followed exactly, a fire or explosion may result causing property damage, personal injury or death.

- **Do not store or use gasoline or other flammable vapors and liquids in the vicinity of this or any other appliance.**
- **WHAT TO DO IF YOU SMELL GAS**
 - **Do not try to light any appliance.**
 - **Do not touch any electrical switch.**
 - **Do not use any phone in your building.**
 - **Immediately call your gas supplier from a neighbor's phone. Follow the gas supplier's instructions.**
 - **If you cannot reach your gas supplier, call the fire department.**
- **Installation and service must be performed by a qualified installer, service agency or the gas supplier.**
(In Massachusetts a licensed plumber / gas fitter)
- **Note to the installer:**
Please leave this instruction book with the consumer for the local electrical / gas inspector's use.

IMPORTANT SAFETY INSTRUCTIONS	4
Guide to the combiset	9
Before using the combiset	11
Use	12
Fast-Ignition-System	12
Turning on and off / Regulating	12
On/Off indicator and Residual heat indicator	13
Cookware	14
Pan size	14
Suitable pans	14
Safety features	15
Ignition safety control	15
Safety cut-off	15
Cleaning and care	16
Burners	17
Frequently asked questions	18
Technical Service	21
IMPORTANT SAFETY INSTRUCTIONS	24
Installation	27
Installation dimensions	28
Cut out	29
Installation of multiple appliances	30
Attach the spring clips and support bars	33
Installing the appliance	35
Removing the appliance	35
Sealing	36
Tiled surfaces	36
Electrical connection	37
Gas connection	39
Gas pressure regulator	40
Nominal ratings	41
Converting to another type of gas	42
Help protect our environment	43

IMPORTANT SAFETY INSTRUCTIONS

WARNING- When using your gas appliance follow basic precautions, including the following:

This gas combiset conforms to all uniform safety codes and regulations. The manufacturer cannot be held responsible for damage or injury caused by improper use of this appliance.

Read all instructions before installation or use to prevent injury and appliance damage.

Keep these operating instructions in a safe place and pass them on to any future user.

SAVE THESE INSTRUCTIONS

Correct usage

▶ Only use the gas combiset for residential cooking, and for the purposes described in this manual. Other uses are not permitted and can be dangerous. The manufacturer will not be held liable for damage caused by unauthorized use or improper operation of any kind.

▶ Persons who lack physical, sensory or mental abilities, or experience with the appliance should not use it without supervision or instruction by a responsible person.

Children

▶ Children should not be left unattended in an area where the appliance is in use. Never allow children to sit or stand on any part of the appliance.

Caution: Do not store items of interest to children in cabinets above the appliance. Children climbing on the appliance to reach these items could be injured.

▶ The appliance is hot during use and remains so for some time after being switched off. Keep children away from the appliance.

▶ Keep all pots and pans out of the reach of children. Danger of burning or scalding.

▶ Ensure that any packing material, is disposed of safely and kept out of the reach of children. Danger of suffocation!

IMPORTANT SAFETY INSTRUCTIONS

Technical safety

► Installation, repair and maintenance work should be performed by a Miele authorized service technician. Work by unqualified persons could be dangerous and may void the warranty.

► Before installing the combiset, check for externally visible damage.

Do not operate a damaged appliance. A damaged gas combiset is a hazard.

► Before installation, make sure that the voltage and frequency listed on the data plate correspond with the household electrical supply. This data must correspond to prevent injury and appliance damage. Consult a qualified electrician if in doubt.

► Be certain your appliance is properly installed and grounded by a qualified technician.

► To guarantee the electrical safety of this appliance, continuity must exist between the appliance and an effective grounding system. It is imperative that this basic safety requirement be met. If there is any doubt, have the electrical system of the house checked by a qualified electrician. The manufacturer will not be held responsible for damages caused by the lack, or inadequacy, of an effective grounding system.

► Install the appliance so that the power cord and gas piping do not come into contact with any portion of the combiset which may become hot during use.

► Do not use an extension cord to connect this appliance to electricity. Extension cords do not guarantee the required safety of the appliance.

► Do not operate the appliance until it has been properly installed in the countertop.

► Do not operate any appliance with a damaged cord or plug, or if the appliance has been damaged in any manner. Contact Miele's Technical Service Department.

► Defective components should be replaced by Miele original spare parts only. Only with these parts can the manufacturer guarantee the safety of the appliance.

► Under no circumstance open the outer casing of the appliance.

► While the appliance is under warranty repairs should only be performed by a Miele authorized service technician. Otherwise the warranty is void.

IMPORTANT SAFETY INSTRUCTIONS

▶ Before servicing, turn off the gas valve and disconnect the power supply by either removing the fuse, unplugging the unit or manually “tripping” the circuit breaker.

▶ This equipment has not been designed for maritime use or for use in mobile installations such as aircraft or recreational vehicles. However, under certain circumstances it may be possible for installation in these applications. Please contact the nearest Miele Dealer or the Miele Technical Service Department with specific requirements.

▶ After connecting the appliance test for leaks according to the installation instructions.

▶ If there is any doubt concerning installation contact Miele’s Technical Service Department.

Safety

▶ The appliance is hot during use and remains so for some time after being switched off. Be careful not to touch the appliance if it may still be hot.

▶ Protect your hands with oven mitts or potholders when using the appliance. Use only dry, heat resistant potholders. Moist or damp potholders used on hot surfaces can result in steam burns. Do not let the potholder touch the hot heating elements. Do not use towels or other bulky items near the appliance.

▶ Be sure drafts do not blow flammable material toward the flames or push the flames so that they extend beyond the edges of the pan.

▶ Be aware of loose fitting or hanging garments when operating the combiset, they may present a fire hazard.

▶ Do not heat unopened containers. Built-up pressure may cause the container to burst and result in injury.

 **WARNING - NEVER** use this appliance as a space heater to heat or warm the room. Doing so may result in carbon monoxide poisoning and overheating.

▶ Install the combiset in a room that has sufficient ventilation.

▶ This appliance must not be operated outdoors.

▶ Make sure all components of the gas burner is assembled correctly before using the combiset.

IMPORTANT SAFETY INSTRUCTIONS

- ▶ Do not use pans that extend past the burner grate. Using larger pans may cause the flames to spread out and damage the surrounding countertop or other countertop appliances.
- ▶ For safety and stability, do not use pans with a bottom diameter smaller than the burner grate.
- ▶ Only certain types of glass, ceramic or other glazed cookware are suitable for use on a combiset without breaking due to the sudden temperature change.
- ▶ Do not use containers made of plastic or aluminum. They may melt at high temperatures.
- ▶ The burner grates supplied with the appliance must always be used. Never place a pan on the burner by itself.
- ▶ Do not use aluminum foil to line any part of the combiset.
- ▶ For proper lighting and performance of the burner, keep the igniter clean and dry.
- ▶ Do not heat empty pots or pans, they may be damaged.
- ▶ For safety reasons the flame should be adjusted to be the same size as the bottom of the pan or smaller. Do not use small pans with high flame settings as the flames can climb the sides of the pan.
- ▶ Ensure that the burner is always covered with a pan.
- ▶ Only use cooking utensils suitable for combiset use.
- ▶ Always position pan handles and utensils inward so they do not extend over adjacent work areas, burner or the edge of the combiset.
- ▶ Do not store items on the appliance when not in use. Items could melt or catch fire from residual heat or if the appliance is turned on inadvertently.
- ▶ Never cover the appliance with a cloth. A fire may result.
- ▶ Do not let cooking grease or other flammable materials accumulate on the appliance.
- ▶ Do not use a steam cleaner to clean the appliance. Steam could penetrate electrical components and cause a short circuit.
- ▶ Spills containing salt or sugar should be removed immediately.
- ▶ Do not leave the combiset unattended while in use. Boil-overs cause smoking, and greasy spill-overs may ignite.
- ▶ Do not use water on grease fires. Smother any fire or flame, or use a dry chemical or foam-type extinguisher.
- ▶ Do not flambé under an exhaust hood. Flames could be drawn up into the hood by the suction or the grease filters may ignite.
- ▶ If there is a drawer directly underneath the appliance without a wooden base in between, ensure that no aerosols, combustible liquids or other easily flammable materials are kept in it. If cutlery inserts are to be placed in the drawer, they must be made of a heat-resistant material.

IMPORTANT SAFETY INSTRUCTIONS

▶ Make certain that the power cords of small appliances do not come in contact with the appliance. The insulation of the cable could become damaged. Danger of electric shock!

▶ In the event of damage or defect, turn off the appliance immediately. Turn off the gas shut off valve and disconnect completely from the electrical supply. Contact the Miele Technical Service Department. Do not use the appliance until it has been repaired. Ensure power is not supplied to the appliance while repair work is carried out.

▶ Before discarding an old appliance, disconnect it from the gas and electrical supply, and cut off the power cord to prevent it from becoming a hazard.

The manufacturer cannot be held liable for damage caused by non-compliance with these Important Safety instructions.

**SAVE THESE INSTRUCTIONS
AND REVIEW THEM
PERIODICALLY**

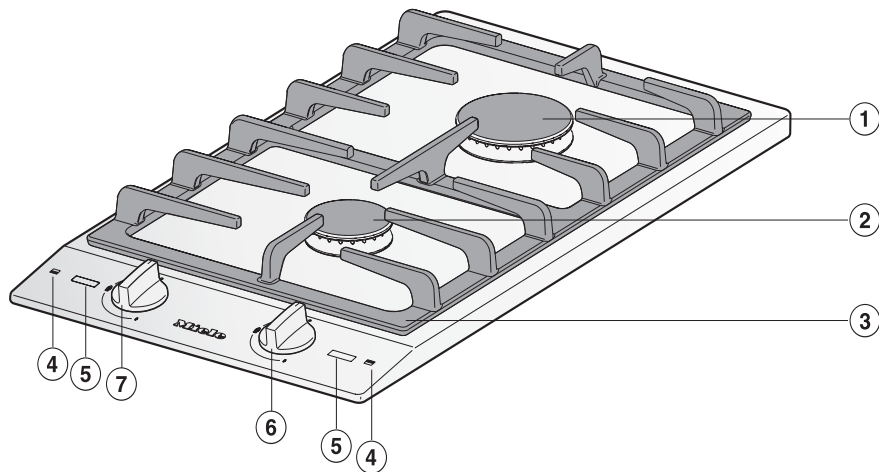

- ① Fast burner
- ② Normal burner
- ③ Burner grate
- ④ Burner indicators
- ⑤ Display

Control knobs:

- ⑥ Rear burner
- ⑦ Front burner

Indicators



- ⑫ On/Off indicator
- ⑬ "Residual Heat" Indicator

Guide to the combiset

Burner

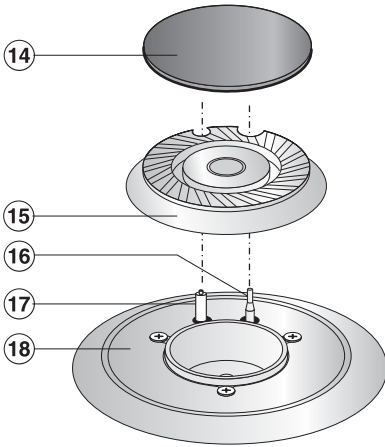

- ⑭ Burner cap
- ⑮ Burner head
- ⑯ Ignition safety control (Thermocouple)
- ⑰ Ignitor
- ⑱ Burner base

Cleaning the combiset

Before using for the first time clean the appliance as follows:

- Remove any protective foil.
- Wash the removable parts of the gas burner in a mild solution of warm water and liquid dish soap.
- Dry and reassemble the parts in the correct order (see "Cleaning and care").
- Wipe down the stainless steel combiset with a suitable cleaner and dry thoroughly.

Metal components have a protective coating which may give off a slight odor the first time your new appliance is heated.

The harmless odor will dissipate after a short time and does not indicate a faulty connection or appliance defect.

Use

Fast-Ignition-System

The gas combisets are equipped with a Fast-Ignition-System which incorporates the following features:

- The control knob does not need to be pressed until the flame lights.
- If the flame goes out because of a draft, for example, the burner is automatically re-ignited. If re-ignition is unsuccessful, the gas supply is automatically interrupted (see "Ignition safety control").

Turning on and off / Regulating

The control knob is used to turn on the burner and to regulate the strength of the flame.

- Combiset is turned off

🔑 Highest flame

🔑 Lowest flame

The knob must only be turned left to turn the appliance **on** and right to turn it **off**.

If the knob is :

- turned on without pressing it down first,
 - turned clockwise to turn on, or
 - turned counterclockwise to turn the combiset off,
- parts of the combiset might get damaged. The manufacturer cannot be held responsible for these damages.

Turning on

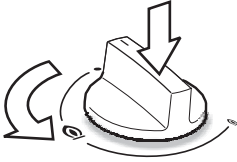

- To turn on the burner, press the control knob down to pass the resistance, then release the pressure and turn it counterclockwise to the largest flame symbol. The ignitor will "click" and ignite the gas.

If the burner does not ignite or the flame goes out, turn the control knob to "●". Try again after a few seconds.

If the burner still won't ignite after the second attempt, turn the control knob to "●" and see "Frequently asked questions".

- Adjust the knob to the desired setting.

Regulating the burners

- The burners can be variably adjusted between the lowest and highest flame by turning the control knob.

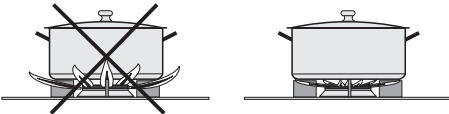

Since the outer portion of the flame is much hotter than the center, the flame should be set so that its tips do not spread beyond the sides of the pan. Flame tips which extend beyond the sides of the pan are hazardous.

Turning off

- Turn the knob clockwise to "●".

This stops the flow of gas and turns off the combiset.

On/Off indicator and Residual heat indicator

When the combiset is turned on, the On/Off indicator lights up. Once a pre-set temperature has been reached, the residual heat indicator will also light up. The On/Off indicator goes out when the combiset is turned off. The residual heat indicator will remain on until the combiset is cool enough to touch.

Do not touch or place any heat sensitive objects on the combiset while the residual heat indicator is on. Danger of damage or injury.

If the display is flashing, a fault has occurred. See "Frequently asked questions".

Cookware

Pan size

- Set the combiset to a high flame when using a large diameter pan and low flame when using a small diameter pan.

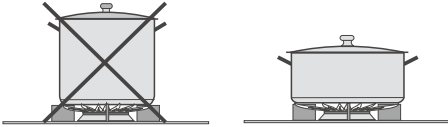

- Generally, wide / shallow pans will heat up quicker and cook more evenly than narrow / tall ones.
- Using oversized pans may cause the flames to spread out and damage the surrounding countertop or other countertop appliances.
- Do not use small pans with high flame settings, the flame may climb the sides of the pan.
- Pots with a smaller diameter than the burner grates and pots that do not sit securely (without wobbling) are hazardous and should not be used.

The burner grates supplied with the appliance must always be used. Never place a pan on the burner by itself.

Suitable pans

Any heat resistant pan can be used on a gas burner.

Unlike pans used on an electric combiset, the bases do not need to be even for good results.

Thick pan bases will give more even results, hot spots are reduced due to better heat distribution.

Thin pan bases will conduct the heat faster but not as evenly as thick pan bases. Stir the food frequently to prevent burning.

Whenever possible, keep pots and pans covered while cooking. This helps keep in the most possible heat.

Ignition safety control

This appliance is equipped with an Ignition Safety Control. This control cuts the gas supply if the flame goes out and reignition is unsuccessful.

- To reignite the burner, turn the control knob to “●”, then switch the burner on as usual.

Safety cut-off

If a zone has been on for an unusually long period of time (approx. 4 hours), it will automatically shut off.

- To reignite the burner, turn the control knob to “●”, then switch the burner on as usual.

Cleaning and care

Never use a steam cleaner to clean this combiset. Pressurized steam could cause permanent damage to the surface and to components for which the manufacturer cannot accept responsibility.

Do not use any sharp or pointed objects which could damage the seal between the frame and the countertop.

Never use scouring agents, pads, abrasive cleaning agents, or strong cleaners, e.g. oven sprays, stain or rust removers, these could damage the surface of the appliance.

Keep the ignitor in the burner dry. If it gets wet it will not spark.

Dry your combiset thoroughly after cleaning it to prevent lime deposits.

Spills containing salt or sugar should be cleaned immediately.

Combiset

Let the appliance cool to a safe temperature before removing the grates.

- Clean the grates, combiset and knobs with a sponge and a mild solution of warm water and liquid dish soap.
- Soak baked or hardened spills. Dry the combiset and grates thoroughly after cleaning.

The stainless steel surfaces can be cleaned using a non-abrasive stainless steel cleaner.

To help prevent resoiling, a conditioner for stainless steel can also be used. Apply sparingly with even pressure. These cleaning products are available from Miele.

Do not use stainless steel cleaner on or around the **printing**, it may rub off. Use only a soft sponge with some dish liquid and warm water to clean this area.

Burners

The burner can be dismantled and cleaned when cool.

- Remove the burner parts and wash them in a solution of warm water and liquid dish soap. Dry them thoroughly. Make sure that the flame holes are clean and completely dry.
- Wipe the burner base clean with a damp cloth and then dry.
- Gently wipe the ignitor and ignition safety control with a slightly damp cloth, and then wipe dry.

Make sure that no liquid gets into the appliance.

Reassembling the burner

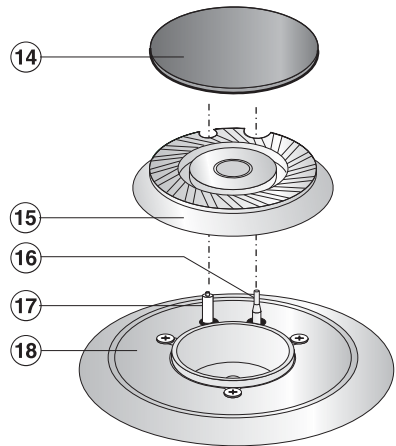

- Place the burner head ⑮ onto the burner base ⑱, making sure that the thermocouple ⑯ and the ignitor ⑰ align through the holes in the burner head. The burner head must fit into place properly.
- Place the burner cap ⑭ evenly onto the burner head ⑮.
Once the burner cap is in the right position, it will not move.

Be careful not to mix up the parts.

Frequently asked questions

 Repairs should only be carried out by an authorized technician in accordance with local and national safety regulations. Unauthorized repairs could cause injury or appliance damage. The manufacturer cannot be held responsible for unauthorized work.

The burner does not ignite when the combiset is being used for the first time or after an extended period of not being used.

Possible fault	Solution
There could be air in the gas pipe.	You may need to make several attempts before the burner ignites successfully.

The On/Off and residual heat indicators are flashing.

Possible fault	Solution
There has been a power failure.	Turn all the controls clockwise to "●". You can now operate the appliance as normal.

The On/Off indicator is flashing.

Possible fault	Solution
The gas supply has been cut-off.	<ul style="list-style-type: none">– Turn all the controls clockwise to position "●". You can now operate the appliance as normal.– If the problem persists, disconnect the appliance from the electrical supply for a few seconds.

Frequently asked questions

The burner does not ignite after several attempts.	
Possible fault	Solution
Disconnect the appliance from the electrical supply for a few seconds. If the problem persists, check if:	
<ul style="list-style-type: none">- The burner is assembled incorrectly.- The gas valve is closed.- The burner is wet and soiled.- The flame slits are dry and unblocked	<ul style="list-style-type: none">- Reassemble the burner as shown in "Cleaning and Care - Burners".- Open the gas valve.- Clean the burners. See "Cleaning and Care".- Dry the igniters.
The flame goes out after being lit.	
Possible fault	Solution
The flames are not touching the ignition safety control. Check if:	
<ul style="list-style-type: none">- The burner is assembled incorrectly.- There is no soiling on the ignition safety control.	<ul style="list-style-type: none">- Reassemble the burner as shown in "Cleaning and Care - Burners".- See "Cleaning and Care".
The flame appears different than usual.	
Possible fault	Solution
The burner is assembled incorrectly.	Reassemble the burner as shown in "Cleaning and Care - Burners".
The flame goes out during operation.	
Possible fault	Solution
The burner is assembled incorrectly.	Reassemble the burner as shown in "Cleaning and Care - Burners".

Frequently asked questions

The igniter does not spark.	
Possible fault	Solution
The circuit breaker has tripped.	Re-set the circuit breaker. Contact an electrician for assistance if in doubt.
Food has deposited itself between the ignitor and the burner cap.	See "Cleaning and care".
Food has deposited on the ignition safety control.	See "Cleaning and care".
For safety reasons, after a spill on the combiset you may need to wait approx. 5 minutes before you are able to reignite the burner. Wait 5 minutes and ignite the burner as usual.	

In the event of a fault which you cannot easily fix yourself, please contact the Miele Technical Service Department at the address on the back of this booklet.

When contacting Technical Service please quote the serial number and model of the appliance.

Adhere data plate sticker supplied with the appliance below.

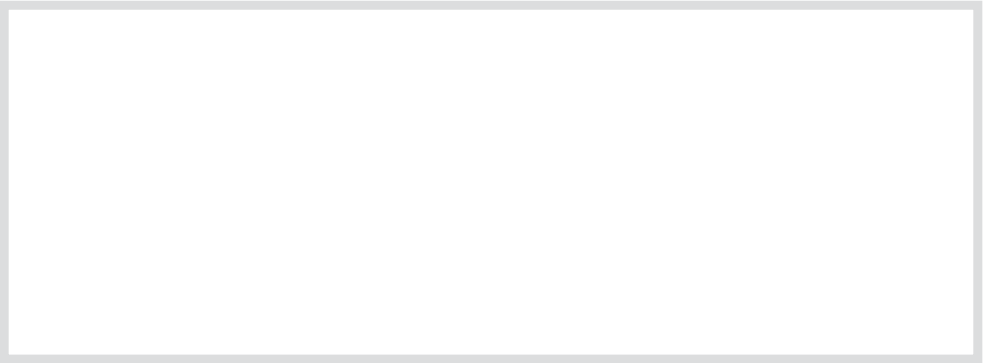

Technical Service

MieleCare

(USA only)

MieleCare, our Extended Service Contract program; gives you the assurance of knowing that your appliance investment is covered by 5 years of worry free ownership.

MieleCare is the only Extended Service Contract in the industry that guarantees repairs by a Miele Authorized Service Provider using genuine Miele parts. Only genuine Miele parts installed by factory trained professionals can guarantee the safety, reliability and longevity of your Miele appliance.

Please note that unless expressly approved in writing by the Miele Service department, Extended Service Contracts offered by other providers for Miele products will not be recognized by Miele. Our goal is to prevent unauthorized (and untrained) service personnel from working on your Miele products, possibly doing further damage to them, you and/or your home.

To learn more about **MieleCare** Extended Service Contracts, please contact your appliance dealer or visit us online at:
<http://miele.com/mielecare>

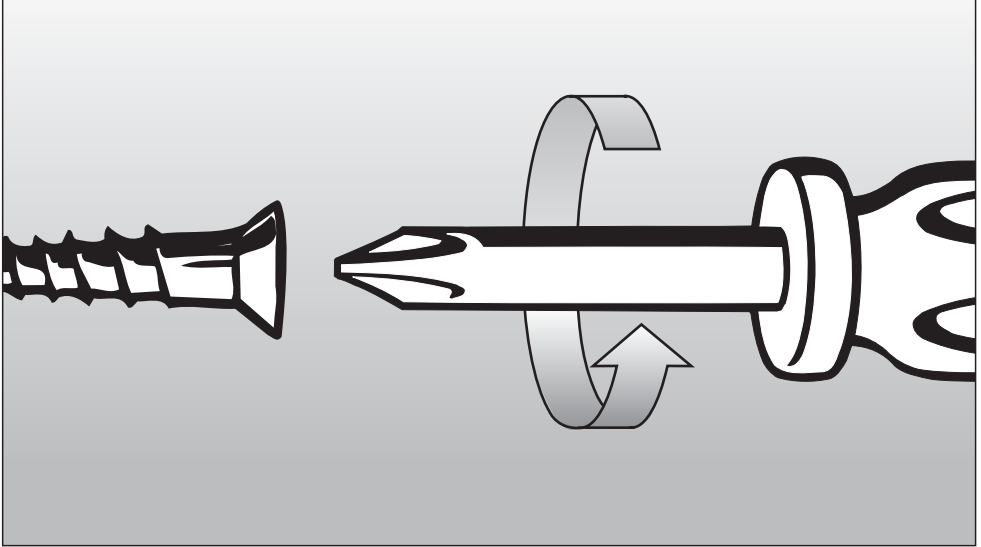

Installation Instructions

IMPORTANT: SAVE FOR THE LOCAL ELECTRICAL INSPECTOR'S USE

To prevent accidents
and machine damage
read these instructions
before
installation or use.

IMPORTANT SAFETY INSTRUCTIONS

Installation

The minimum distances given in these Installation instructions are to combustible surfaces, and must be observed to ensure safe operation. Failure to do so increases the risk of fire.

The cabinetry and venting hood should be installed first to prevent damage to the combiset.

- ▶ Gas appliances should only be installed in a well ventilated area.
- ▶ The countertop must be bonded with heat resistant (212°F/100°C) adhesive to prevent distortion or dissolving.
- ▶ This appliance has not been designed for maritime use or for use in mobile installations such as recreational vehicles or aircraft. However, under certain conditions it may be possible for installation in these applications. Please contact the Miele Technical Service Department with specific requirements.
- ▶ The combiset must not be installed over a dishwasher, washer, dryer, refrigerator or freezer. Heat radiated by the combiset may damage the appliances.

▶ Deep fat fryers must not be installed directly next to gas combisets. Gas flames can ignite splattering oil. A distance of at least 11 5/16" (288 mm) should be maintained between these two appliances.

▶ Install the appliance so that the power cord or gas piping does not come into contact with any portion of the combiset which may become hot during use.

This appliance must be installed with its own shut off valve and the included gas pressure regulator. Both the valve and the regulator must be easily accessible to the consumer after the appliance is installed.

This appliance must be disconnected from the gas supply during any pressure testing of the system performed in excess of ½ psi (3.5 kPa). This appliance must be isolated at test pressures equal to or less than ½ psi (3.5 kPa).

Any pipe connections must be made using a thread sealant approved for gas connections. Failure to correctly install these items could lead to a gas leak and subsequent explosion.

Keep this instruction book in a safe place for reference and pass it on to any future user.

IMPORTANT SAFETY INSTRUCTIONS

Safety distances above the appliance

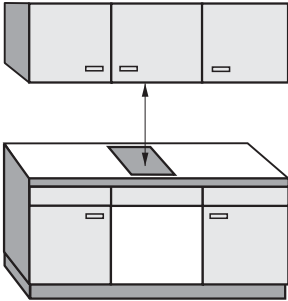

The minimum safety distance given by the hood manufacturer must be maintained between the combiset and the hood above it. See the installation instructions of the hood for these safety measurements.

If the hood manufacturers instructions are not available or if flammable objects are installed over the combiset (e.g. cabinets, utensil rail, etc.), a minimum safety distance of 30" (760 mm) must be maintained.

If there is more than one appliance beneath a hood (e.g. wok burner and electric combiset), and they have different minimum safety distances always observe the greater distance.

IMPORTANT SAFETY INSTRUCTIONS

Safety distances to the sides of the appliance

The appliance should only be installed as shown in the illustrations, while maintaining the required safety distances shown. Do not install the appliance between two tall cabinets, this is a fire hazard.

A distance of at least 2" (50 mm) must be kept between the countertop cut-out and the rear wall because of the high temperatures radiated.

The minimum distance required from the countertop cut-out to the side wall ①:

2" (50 mm)	for	CS 1112 CS 1122 CS 1212 CS 1221 CS 1223 CS 1326 CS 1411
6" (150 mm)	for	CS 1312 CS 1322 CS 1421
10" (250 mm)	for	CS 1011 CS 1012 CS 1028

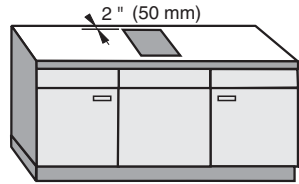
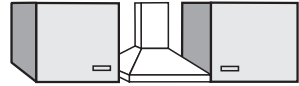

recommended

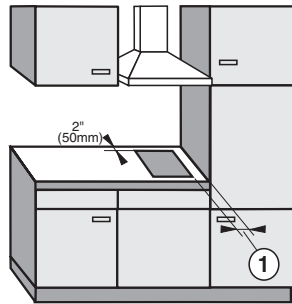

not recommended

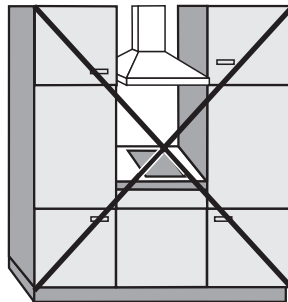

not allowed

Safety distance when installing the appliance near a wall with trim or a back splash

A minimum distance of 2" (50 mm) between the trim or back splash and the countertop cut-out if required.

This distance is only necessary if these items are made of combustible materials e.g. wood. If the trim or back splash is made of a non-combustible material, the required safety distance can be reduced by the thickness of the wall covering material.

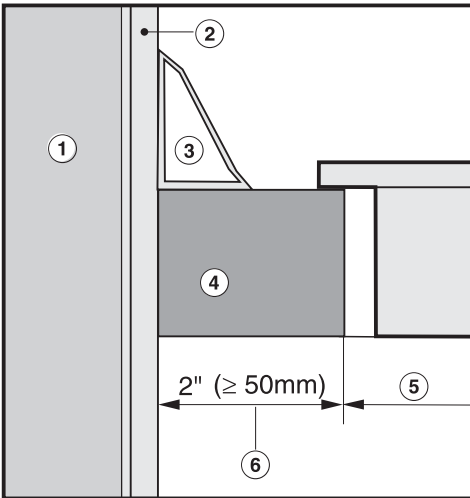

- ① Wall frame
- ② Sheet rock or wall board
- ③ Trim or back splash
- ④ Countertop
- ⑤ Countertop cut-out
- ⑥ 2" (50 mm) minimum clearance

Cut out

- Make the countertop cut-out for the desired number of appliances. Remember to maintain a **minimum safety distance** from the **back wall**, as well as from any **tall unit or side wall** to the left or right of the combiset.
See also the "IMPORTANT SAFETY INSTRUCTIONS".
- Seal the cut surfaces with a suitable sealant to avoid swelling caused by moisture.
The materials used must be heat resistant.

If during installation the seal around the frame does not sit flush with the countertop in the corners, the corner radius, maximum $\frac{3}{16}$ " (4 mm), can be carefully filed down to fit.

Installation

Installation of multiple appliances

When installing more than one combiset appliance, a support bar ② must be installed between the appliances.

Countertop cut-out two appliances

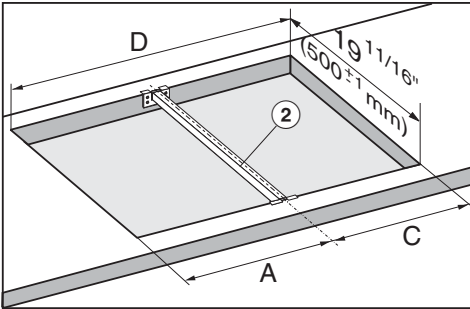

For the installation of **two appliances** the width of the countertop cut-out D is the sum of A and C.

A, B and C = appliance width
11 5/16", 15" or 22 11/16"
(288 mm, 380 mm or 576 mm)
minus 5/16" (8 mm) to allow for the overhang

D = width of the countertop cut-out

Countertop cut-out three appliances

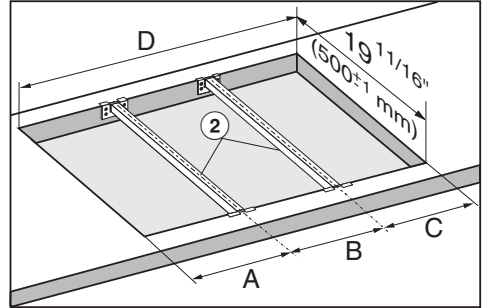

For the installation of **three appliances** the width of the countertop cut-out D is the sum of A and B and C.

If **more than three appliances** are being installed, you will need to add, A, B or C for each additional appliance.

Sample calculations for a countertop cut-out for three appliances

A appliance width minus 5/16" (8 mm)	B appliance width	C appliance width minus 5/16" (8 mm)	D Countertop cut-out
11" (280 mm)	11 5/16" (288 mm)	11" (280 mm)	33 3/8" (848 mm)
11" (280 mm)	15" (380 mm)	14 5/8" (372 mm)	40 5/8" (1032 mm)
11" (280 mm)	22 11/16" (576 mm)	22 3/8" (568 mm)	56 1/16" (1424 mm)
14 5/8" (372 mm)	11 5/16" (288 mm)	11" (280 mm)	37" (940 mm)
14 5/8" (372 mm)	15" (380 mm)	14 5/8" (372 mm)	44 1/4" (1124 mm)
14 5/8" (372 mm)	22 11/16" (576 mm)	22 3/8" (568 mm)	59 11/16" (1516 mm)
22 3/8" (568 mm)	11 5/16" (288 mm)	11" (280 mm)	44 3/4" (1136 mm)
22 3/8" (568 mm)	15" (380 mm)	14 5/8" (372 mm)	52" (1320 mm)
22 3/8" (568 mm)	-	22 3/8" (568 mm)	44 3/4" (1136 mm)

Installation

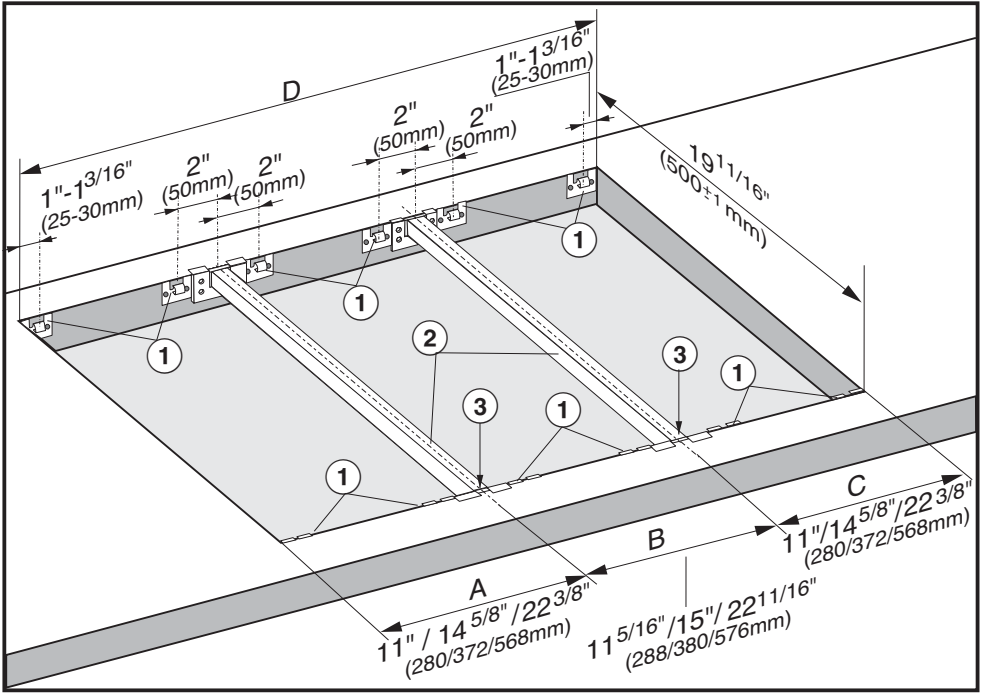

- ① Spring clips
- ② Support bars
- ③ Space between support bar and countertop

An additional support bar is required for each additional appliance. The position for attachment of an additional spacing strip depends on the width of the appliance **B**.

Attach the spring clips and support bars

Wood or solid surface countertops

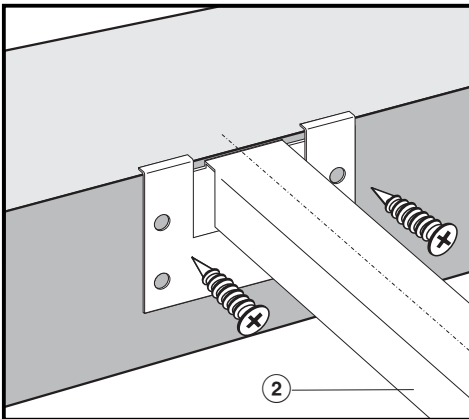
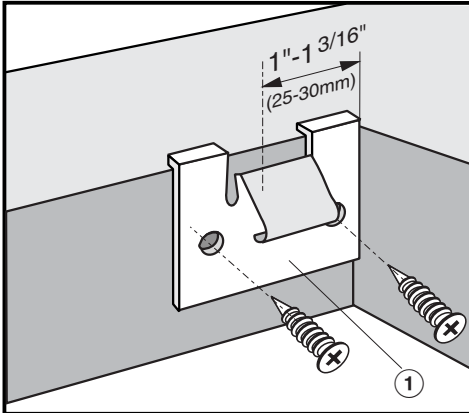

- Place the supplied spring clips ① and the support bars ② at the marked positions as shown above, by laying them on the upper edge of the cut-out and then securing them with the $\frac{1}{8}$ " x 1" (3.5 x 25 mm) screws (supplied).

Granite countertop

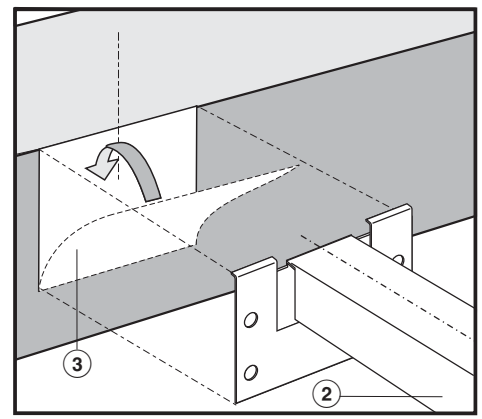
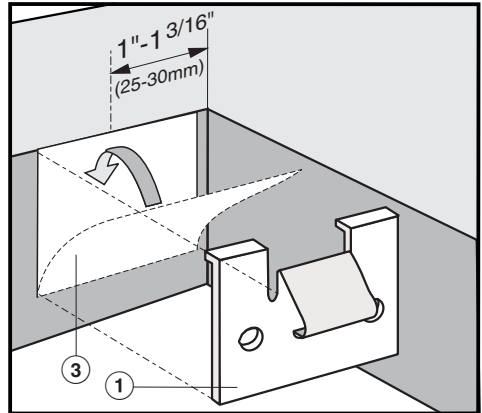

- Position and attach the spring clips ① and support bars ② with strong, double-sided tape ③.

The screws are not needed for granite countertops.

Installation

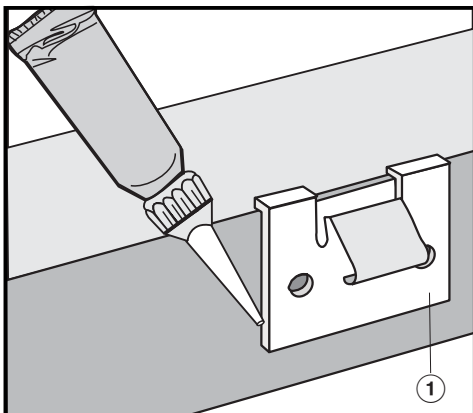

- Coat the edges of the spring clips ①,

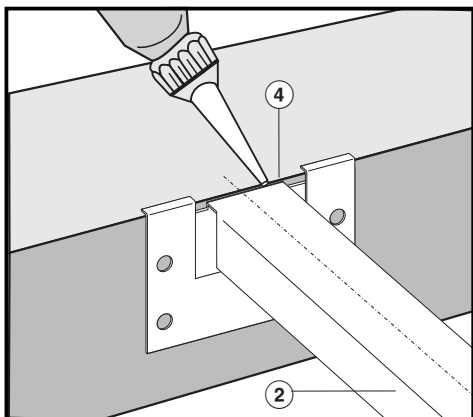

- and the space ④ between the support bars ② and the countertop with silicone (supplied).

Installing the appliance

- Feed the power cord down through the cut-out.
- Then place the front side of the appliance in the countertop cut-out.
- Then with a hand on each side of the appliance press down evenly on the edges until it clicks into position. When doing so make sure that the appliance seal sits tightly on the countertop to ensure it is sealed correctly. **Do not** permanently seal into the countertop.
- Connect the appliance to the main power supply.
- Turn the appliance on and check the function.

Removing the appliance

If the appliance is accessible **from below**, it can be pushed up and out of the cut-out. Push up from the back first.

If the appliance is **not accessible from below**, grip the appliance with both hands at the back, pull forward, then lift it up and out.

Installation

Sealing

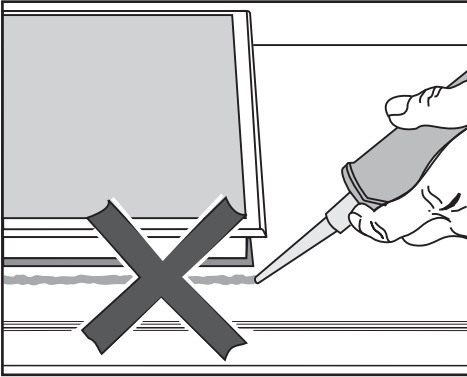

The appliance must not be permanently sealed into the countertop when installed. The sealing strip under the edge of the appliance provides a sufficient seal for the countertop.

If the appliance is sealed into position, the countertop or appliance could be damaged if it needs to be removed for maintenance or service.

Tiled surfaces

The grouting ① and shaded area under the appliance frame must be flat and even so that the frame will lie evenly and the sealing strip under the edge of the upper part of the appliance can provide an adequate seal against the countertop.

This appliance must be grounded according to local or national codes.

All electrical work should be performed by a qualified electrician in accordance with local codes and with the:

- National Electrical Code ANSI / NFPA No. 70 for the USA
- or
- Canadian Electrical Code Part I for Canada (CSA Standard C 22.1).

WARNING

Disconnect the appliance from the main power supply before installation or service. To reduce the risk of electric shock, make sure that the appliance is properly grounded after installation.

This appliance is equipped with a three-prong grounding plug to prevent shock hazards. It should be plugged directly into a properly grounded outlet. Do not cut or remove the grounding prong from the plug. If the plug does not fit the outlet, have the proper outlet installed by a licensed electrician.

To guarantee the electrical safety of this appliance, continuity must exist between the appliance and an effective grounding system. It is imperative that this basic safety requirement be met. If there is any doubt, have the electrical system of the house checked by a qualified electrician.

The manufacturer cannot be held responsible for damages caused by the lack, or inadequacy, of an effective grounding system.

Power supply

The automatic ignition requires that the combiset be connected to a 120 VAC, 60 Hz power supply. The supply line should be protected by a 15 A fuse.

Actual power consumption (during ignition only) is 25 W.

This appliance is equipped with a 78 3/4" (2000 mm) long power cord that is ready for connection to the appropriate outlet.

Place the power outlet so that it is accessible after the appliance has been installed in the countertop.

Note to the installer

Please leave these instructions with the consumer or the appliance.

Electrical connection

Wiring Diagram

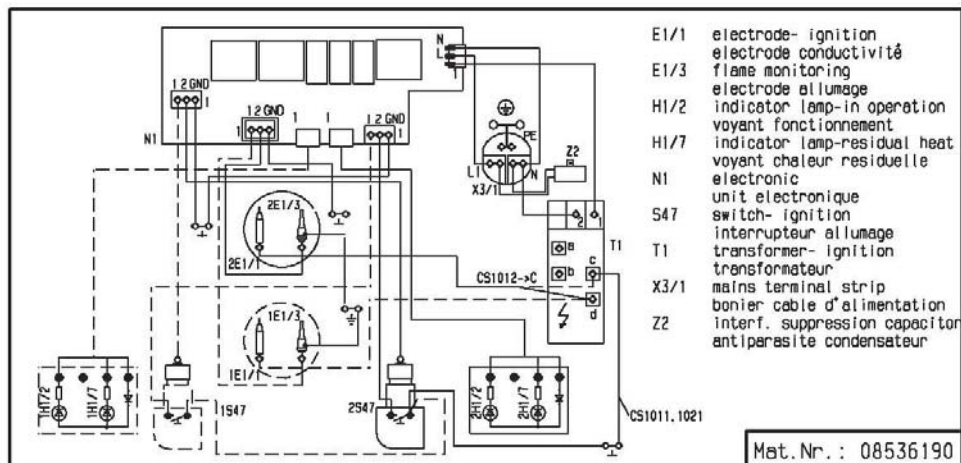

Installation and service must be performed by a qualified installer, service agency or the gas supplier.

In Massachusetts a licensed plumber/gas fitter is required.

This appliance must be installed with its own shut off valve and the included gas pressure regulator. Both the valve and the regulator must be easily accessible to the consumer to turn on or shut off the gas supply after the appliance is installed.

This appliance and its individual shut off valve must be disconnected from the gas supply during any pressure testing performed in excess of ½ psi (3.5 kPa), or isolated from the gas line by closing its individual manual shut off valve at test pressures equal to or less than ½ psi (3.5 kPa).

Any pipe connections must be made using a thread sealant approved for gas connections. Failure to correctly install these items could lead to a gas leak and subsequent explosion.

The gas connection must be made in accordance with local codes or, in the absence of local codes, with

- the National Fuel Gas Code, ANSI Z 223.1/NFPA 54 for the USA
- or
- the current Can/CGA B 149.1 and .2 Installation Codes for gas burning appliances for Canada.

Make sure that the maximum gas supply pressure before the gas pressure regulator is never more than ½ psi for both natural gas or LP gas.

The minimum supply pressure to get the required gas input is
4" w.c. for natural gas:
10" w.c. for LP gas.

Gas connection

Gas pressure regulator

A pressure regulator that is convertible from natural to LP gas (Propane) or vice versa is included with the appliance. The included regulator corresponds with the gas type of the combiset. Verify before installing.

The adjusted pressure is:
natural gas - 4" w.c.
LP gas - 10" w.c.

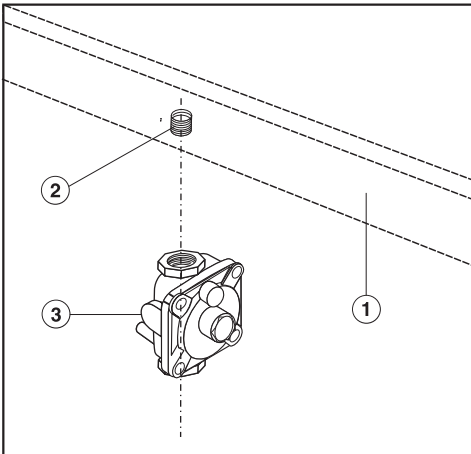

- ① Combiset
- ② 1/2" NPT
- ③ Regulator

As shown in the above diagram, the included regulator **must** be used when connecting the Miele combiset to your gas supply. This item has been customized by Miele to meet all applicable safety requirements. Make sure the regulator is easily accessible for adjustment after the appliance has been installed.

For convenience, an AGA or CGA approved flexible stainless steel gas hose (accordion type) may be used between the gas connection and the regulator. This will allow the appliance to be lifted out of the countertop for cleaning or servicing. Make sure that any drawers, cabinet doors, etc., do not rub on this gas hose.

Do not use any regulator unless it has been supplied by Miele. Doing so may cause a gas leak.

If there is any doubt concerning installation contact the Miele Technical Service Department.

After connecting the appliance check all fittings for gas leaks e.g. with soapy water.

When installed properly, the flame will be steady and quiet. It will also have a sharp, blue inner core that will vary in length proportional to the burner size. Flame adjustment will not be necessary.

Nominal ratings

Maximum output

	Gas type	BTU/hr	kW
Normal burner	Natural Gas (NG)	5,700	1.65
	Propane (LP)	5,000	1.45
Fast burner	Natural Gas (NG)	10,600	3.10
	Propane (LP)	9,300	2.75
Total output	Natural Gas (NG)	16,300	4.75
	Propane (LP)	14,300	4.2

Minimum output

	Gas type	BTU/hr	kW
Normal burner	Natural Gas (NG)	775	0.227
	Propane (LP)	1,010	0.296
Fast burner	Natural Gas (NG)	1,550	0.454
	Propane (LP)	1,500	0.439

Converting to another type of gas

The combiset should have been ordered for connection to either natural gas or LP gas (propane).

If the combiset is not configured for the proper type of gas connection please contact your Miele Dealer.

If the appliance is to be connected to a type of gas other than it was originally configured for, both the regulator and burner must be converted. A conversion kit is available as an optional accessory from the Miele Technical Service Department.

Help protect our environment

Disposal of packing materials

The cardboard box and packing materials are biodegradable and recyclable. Please recycle.

Ensure that any plastic wrappings, bags, etc. are disposed of safely and kept out of the reach of children.

Danger of suffocation!

Disposal of an old appliance

Old appliances contain materials that can be recycled. Please contact your local recycling authority about the possibility of recycling these materials.

Before discarding an old appliance disconnect it from the electrical supply and cut off the power cord to prevent it from becoming a hazard.

Please have the model and serial number of your appliance available before contacting Technical Service.



**U.S.A.
Miele, Inc.**

National Headquarters

9 Independence Way
Princeton, NJ 08540
Phone: 800-843-7231
609-419-9898
Fax: 609-419-4298
www.miele.com

**Technical Service & Support
Nationwide**

Phone: 800-999-1360
Fax: 888-586-8056
TechnicalService@mieleusa.com

**Canada
Miele Limited**

Headquarters and Showroom

161 Four Valley Drive
Vaughan, ON L4K 4V8
Phone: 800-643-5381
905-660-9936
Fax: 905-532-2290
www.miele.ca
info@miele.ca (general enquiries)
professional@miele.ca (commercial enquiries)

MieleCare National Service

Phone: 800-565-6435
905-532-2272
Fax: 905-532-2292
customercare@miele.ca (technical enquiries)