

# Gibson®



*Home Comfort Products*

## How To Choose An Air Conditioner

Measure the length and width of the area to be cooled. Multiply the length by the width to determine Sq. Ft. or Sq. m. Locate the Sq. Ft. or Sq. m in the columns below. Choose a BTU size from the chart for the area to be cooled.

ROOM SIZE			ROOM SIZE		
Sq. Ft.	Sq. m	BTU	Sq. Ft.	Sq. m	BTU
150	14	Up to 5,000	880	82	15,100
350	33	8,000	1,170	103	18,500
490	45	10,000	1,670	154	25,000
640	60	12,000			

When cooling rooms with uninsulated ceilings, great rooms, or southern or western sun exposures – step up to the next BTU size or consult your sales professional.

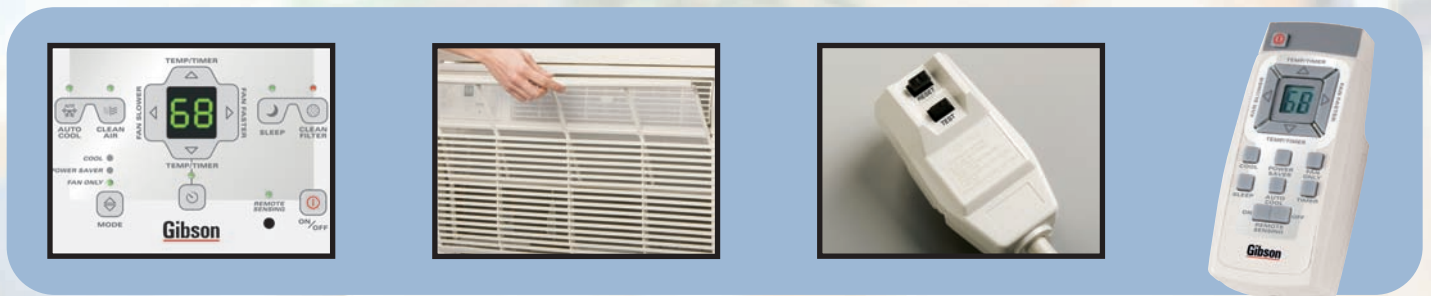

## Room Air Conditioner Key Features

**Electronic Controls** coupled with full-function remote capabilities give the consumer control flexibility at the remote and the unit. Cool, energy saver and fan modes, On/Off 24-hour timer; auto cool and sleep can be programmed with the remote. Electronic controls offer filter check reminder and clean air features.

**Antibacterial Air Filtration** results in health benefits by preventing the circulation of harmful bacteria that cause many illnesses and allergies. The washable mesh filter is coated to destroy this unhealthy bacteria for the life of the air conditioner.

**All Room Air Conditioners** are now manufactured with an LCDI (Leakage Current Detection and Interruption) device. This device enhances the product's safety by checking for cord damage. It monitors current flow and trips if the cord is not operating properly.

**Temperature-Sensing Remote** available on some models. Controls temperature at the remote or the unit, depending on the customer's preference. The remote can be placed anywhere in the same room as the unit, providing a greater level of comfort.

**LVC Technology** is available on all Multi-Step Fan Speed models and ensures proper operation of the unit when voltage fluctuates.

# Home Comfort Products

The Gibson® lineup of air conditioners work hard to enhance the comfort of your home. Offering a broad range of models with features like antibacterial filtration and LCDI cord protection, Gibson® Home Comfort products are designed to provide you with easy-to-use, efficient and reliable service.



## MINI SERIES

- 5,000 BTUH cooling capacity
- Rotary fan 2-speed control
- Cools up to 150 sq. ft. rooms
- 2-way air direction control
- Slide-out filter access
- See specifications chart for specific model features
- Pleated quick mount window kit included for clean installation



## MINI COMPACT SERIES

- 8,000 BTUH cooling capacity
- Rotary fan 3-speed control
- Cools up to 350 sq. ft. rooms
- 8-way air direction control
- Tilt-out filter access
- See specifications chart for specific model features
- Pleated quick mount window kit included for clean installation



## COMPACT SERIES

- 10,000 to 12,000 BTUH cooling capacity
- Rotary fan 3-speed control
- Cools up to 640 sq. ft. rooms
- 8-way air direction control
- Tilt-out filter access
- See specifications chart for specific model features
- Pleated quick mount window kit included for clean installation



## MEDIAN SERIES



- 15,000 to 18,500 BTUH cooling capacity
- Units have full-function electronic controls with remote
- Cools up to 1,170 sq. ft. rooms
- Multi-directional air direction control
- Available in 115 or 230 / 208 voltage
- Tilt-out filter access
- Antibacterial mesh filter
- See specifications chart for specific model features
- ENERGY STAR® models available
- Pleated quick mount window kit included for clean installation



## HEAVY-DUTY SERIES



- 22,000 to 25,000 BTUH cooling capacity
- Units have full-function electronic controls with remote
- 3 fan speeds
- Cools up to 1,670 sq. ft. rooms
- Multi-directional air direction control
- Available in 115 or 230 / 208 voltage
- Tilt-out filter access
- Antibacterial mesh filter
- See specifications chart for specific model features
- ENERGY STAR® model available
- Pleated quick mount window kit included for clean installation



## THROUGH-THE-WALL SERIES



- Units that cool and heat available
- 8,000 to 12,000 BTUH cooling capacity
- 10,600 BTUH heating capacity on heat and cool model
- 3 fan speeds
- Units have full-function electronic controls with remote
- Temperature sensing remote controls with thermostat available on cool only model
- Cools or heats up to 640 sq. ft. rooms
- 4-way air direction control
- Fits all existing wall sleeves
- Optional window mounting kit available
- Included standard universal interior trim kit allows the unit to neatly fit into any existing sleeve
- Available in 230 / 208 voltage
- See specifications chart for specific model features
- ENERGY STAR® models available
- Universal trim kit covers space between the sleeve and unit



## SLIDER/CASEMENT SERIES



- 8,000 to 10,000 BTUH cooling capacity
- 3 fan speeds
- Units have full-function electronic controls with remote
- Cools up to 490 sq. ft. rooms
- 4-way air direction control
- Easy mount window kit included
- ENERGY STAR® model available
- See specifications chart for specific model features

	MINI	MINI COMPACT	COMPACT	
Model	GAX052P7A	GAA082P7A	GAC102P1A	GAC122P1A
Series	Gibson	Gibson	Gibson	Gibson
<b>Performance</b>				
BTU (Cool)	5,000	8,000	10,000	12,000
Dehumidification (Pints / Hour)	1.1	2.1	3.0	3.8
Cool Area (Sq. Ft.)	150	350	500	640
EER	9.7	9.8	9.8	9.8
<b>Electrical</b>				
Volts	115	115	115	115
Amps (Cool)	5.1	7.4	9.2	10.7
Watts (Cool)	515	815	1,020	1,220
Length of Power Cord	6'	6'	6'	6'
Plug Type (NEMA)*	LCDI (A)	LCDI (A)	LCDI (A)	LCDI (A)
<b>Features</b>				
Controls	Mechanical	Mechanical	Mechanical	Mechanical
Fan Speeds (Cool / Fan / Heat)	2 / 2 / -	3 / 3 / -	3 / 3 / -	3 / 3 / -
Low Voltage Start-Up	•	•	•	•
Auto Cool Function				
Energy Save				
Sleep Mode				
Filter Check				
24 Hour On / Off Timer				
Remote Control				
Air CFM (High / Med / Low)	150 / - / 110	220 / 185 / 155	295 / 250 / 215	295 / 250 / 215
Air Direction Control	2-Way	8-Way	8-Way	8-Way
Fresh Air / Exhaust Vent / Closed	No / No / Yes	No / No / Yes	Yes / Yes / Yes	Yes / Yes / Yes
Filter Type	Antibacterial Mesh	Antibacterial Mesh	Antibacterial Mesh	Antibacterial Mesh
Filter Access	Slide-Out	Tilt-Out	Tilt-Out	Tilt-Out
Cabinet Louvers	•	•	•	•
Window Mounting Kit	Pleated Quick Mount	Pleated Quick Mount	Pleated Quick Mount	Pleated Quick Mount
<b>Dimensions</b>				
A - Cabinet Height	11-1/2"	12-1/2"	14"	14"
B - Cabinet Width	15-1/2"	18-1/2"	19"	19"
C - Cabinet Depth (with Front)	12"	14" (15-1/2")	19-3/4" (21-1/4")	19-3/4" (21-1/4")
D - Window Height (Min.)	13"	14"	14-1/4"	14-1/4"
E - Window Width (Min. / Max.)	23" / 36"	23" / 36"	23" / 36"	23" / 36"
Carton Height	15"	14-3/4"	16-3/4"	16-3/4"
Carton Width	18-1/16"	21-3/4"	22-1/4"	22-1/4"
Carton Depth	15-1/4"	18-1/4"	23-1/4"	23-1/4"
Unit Weight	40 Lbs.	53 Lbs.	74 Lbs.	79 Lbs.
Shipping Weight	44 Lbs.	61 Lbs.	83 Lbs.	88 Lbs.
UPC (0-12505)	27235-6	27236-3	27237-0	27238-7

### Mini, Mini Compact & Compact Models

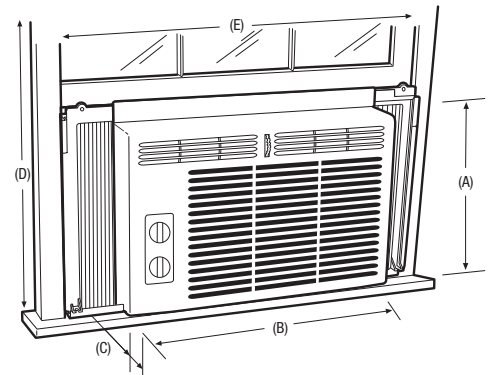

\* Plug Type (NEMA)

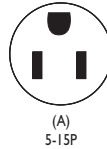

(A)  
5-15P

### Median & Heavy-Duty Models

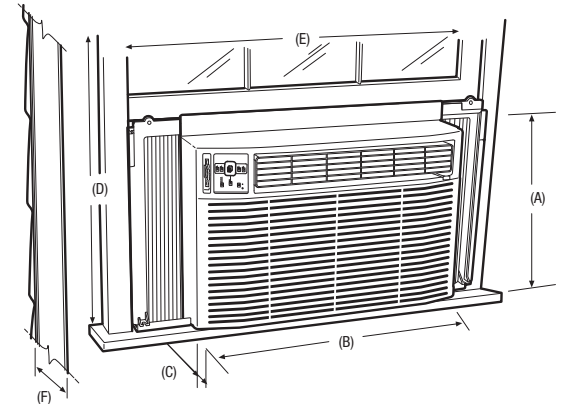

\* Plug Type (NEMA)



(A)  
5-15P



(B)  
6-15P

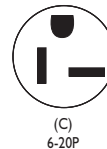

(C)  
6-20P

	MEDIAN		HEAVY-DUTY
Model	GAM155Q1A	GAM154Q1A	GAS256Q2A
Series	Gibson	Gibson	Gibson
ENERGY STAR®			
<b>Performance</b>			
BTU (Cool)	15,100	15,100	18,000 / 17,800
Dehumidification (Pints / Hour)	3.5	3.5	5.5
Cool Area (Sq. Ft.)	900	900	1,170
EER	10.7	10.7	9.7
<b>Electrical</b>			
Volts	115	115	230 / 208
Amps (Cool)	12.5	12.5	8.3 / 8.8
Watts (Cool)	1,410	1,410	1,855 / 1,835
Length of Power Cord	6'	6'	5.7'
Plug Type (NEMA)*	LCDI (A)	LCDI (A)	LCDI (B)
<b>Features</b>			
Controls	Electronic	Electronic	Electronic
Fan Speeds (Cool / Fan / Heat)	VS Electronic	3 / 3 / -	3 / 3 / 3
Low Voltage Start-Up	•	•	•
Auto Cool Function	•	•	•
Energy Save	•	•	•
Sleep Mode	•	•	•
Filter Check	•	•	•
24 Hour On / Off Timer	•	•	•
Remote Control	Full-Function	Full-Function	Full Function with Heat & Remote T'Stat
Air CFM (High / Med / Low)	489 / 406 / 330	489 / 406 / 330	489 / 430 / 347
Air Direction Control	Auger Multi	Auger Multi	Auger Multi
Fresh Air / Exhaust Vent / Closed	Yes / Yes / Yes	Yes / Yes / Yes	Yes / Yes / Yes
Filter Type	Antibacterial Mesh	Antibacterial Mesh	Antibacterial Mesh
Filter Access	Tilt-Out	Tilt-Out	Tilt-Out
Slide-Out Chassis	•	•	•
Cabinet Louvers	•	•	•
Rear Grille	•	•	•
Window Mounting Kit	Pleated Quick Mount	Pleated Quick Mount	Pleated Quick Mount
<b>Dimensions</b>			
A - Cabinet Height	17-3/4"	17-3/4"	17-3/4"
B - Cabinet Width	23-5/8"	23-5/8"	23-5/8"
C - Cabinet Depth (with Front)	24" (25-3/8")	24" (25-3/8")	24" (25-3/8")
D - Window Height (Min.)	18-1/2"	18-1/2"	18-1/2"
E - Window Width (Min. / Max.)	26-1/2" / 40-1/2"	26-1/2" / 40-1/2"	26-1/2" / 40-1/2"
F - Max. Wall Thickness	9-1/4"	9-1/4"	9-1/4"
Carton Height	19-3/4"	19-3/4"	19-3/4"
Carton Width	26"	26"	26"
Carton Depth	30-1/4"	30-1/4"	30-1/4"
Unit Weight	117 Lbs.	117 Lbs.	134 Lbs.
Shipping Weight	132 Lbs.	132 Lbs.	149 Lbs.
UPC (0-12505)	27239-4	27250-9	27251-6

### INSTALLATION

The following dimension and cutout information is for planning purposes only. For complete installation details consult manual packed with product, or download manual at [Customer Service, online at frigidaire.com](http://Customer Service, online at frigidaire.com).



## THROUGH-THE-WALL

Model	GAH085Q1T	GAH105Q2T	GAH126R2T	GAH124Q2T	GAH12ER2T
Series	Gibson		Gibson	Gibson	Gibson
ENERGY STAR®					
<b>Performance</b>					
BTU (Cool)	8,000	10,000 / 9,800	12,000 / 11,700	12,000 / 11,700	12,000 / 11,700
BTU (Heat)					10,600 / 8,600
Dehumidification (Pints / Hour)	1.8	2.1	3.5	3.0	3.5
Cool Area (Sq. Ft.)	350	500	640	640	640
EER	9.4	9.4	9.0	9.0	9.0
<b>Electrical</b>					
Volts	115	230 / 208	230 / 208	230 / 208	230 / 208
Amps (Cool)	8.0	4.8 / 5.1	6.0 / 6.7	5.7 / 6.4	6.0 / 6.5
Amps (Heat)					16.0 / 14.5
Watts (Cool)	850	1,060 / 1,045	1,335 / 1,300	1,335 / 1,300	1,335 / 1,300
Watts (Heat)					3,450 / 2,800
Length of Power Cord	6'	6'	4.5'	6'	4.5'
Plug Type (NEMA)*	LCDI (A)	LCDI (B)	LCDI (B)	LCDI (B)	LCDI (C)
<b>Features</b>					
Controls	Electronic	Electronic	Electronic	Electronic	Electronic
Fan Speeds (Cool / Fan / Heat)	3 / 3 / -	3 / 3 / -	3 / 3 / -	3 / 3 / -	3 / 3 / 3
Low Voltage Start-Up	•	•	•	•	•
Auto Cool Function	•	•	•	•	•
Energy Save	•	•	•	•	•
Sleep Mode	•	•	•	•	•
Filter Check	•	•	•	•	•
24 Hour On / Off Timer	•	•	•	•	•
Remote Control	Full-Function	Full-Function	Full-Function & Remote T Stat	Full-Function	Full-Function with Heat
Air CFM (High / Med / Low)	223 / - / 182	277 / - / 247	264 / - / -	300 / - / 270	264 / - / -
Air Direction Control	4-Way	4-Way	4-Way	4-Way	4-Way
Fresh Air / Exhaust Vent / Closed	No / No / Yes	No / No / Yes	No / No / Yes	No / No / Yes	No / No / Yes
Filter Type	Antibacterial Mesh	Antibacterial Mesh	Antibacterial Mesh	Antibacterial Mesh	Antibacterial Mesh
Filter Access	Slide-Out	Slide-Out	Slide-Out	Slide-Out	Slide-Out
Rear Grille	•	•	•	•	•
Window Mounting Kit	Universal Trim Kit	Universal Trim Kit	Universal Trim Kit	Universal Trim Kit	Universal Trim Kit
<b>Dimensions</b>					
A - Cabinet Height	14-1/2"	14-1/2"	14-1/2"	14-1/2"	14-1/2"
B - Cabinet Width	24"	24"	24"	24"	24"
C - Cabinet Depth (with Front)	22" (23-1/2")	22" (23-1/2")	19" (20-1/2")	22" (23-1/2")	19" (20-1/2")
D - Max. Wall Thickness	18"	18"	18"	18"	18"
Carton Height	17-1/2"	17-1/2"	17"	17-1/2"	17"
Carton Width	26-3/4"	26-3/4"	27"	26-3/4"	27"
Carton Depth	28-1/2"	28-1/2"	28"	28-1/2"	28"
Unit Weight	75 Lbs.	86 Lbs.	86 Lbs.	88 Lbs.	91 Lbs.
Shipping Weight	97 Lbs.	108 Lbs.	108 Lbs.	110 Lbs.	112 Lbs.
<b>UPC (0-12505)</b>	27254-7	27256-1	27242-4	27257-8	27243-1

## THROUGH-THE-WALL BUILDER SLEEVE

Model	EA108T
<b>Dimensions</b>	
Cabinet Height	15-1/4"
Cabinet Width	25-1/2"
Cabinet Depth	17-1/2"
Carton Height	17-1/8"
Carton Width	27-1/6"
Carton Depth	18-8/9"
Unit Weight	25 Lbs.
Shipping Weight	30 Lbs.

\* Plug Type (NEMA)



(A)  
5-15P



(B)  
6-15P



(C)  
6-20P

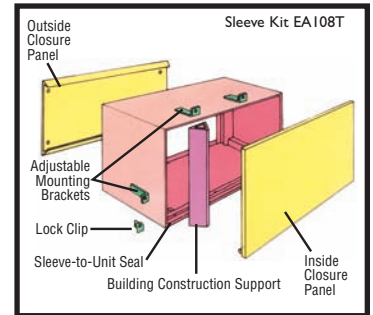

### Through-The-Wall Models

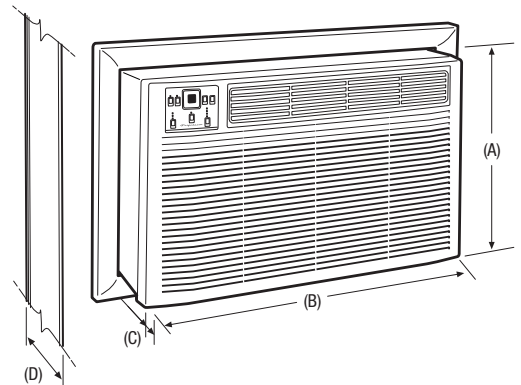

## SLIDER/CASEMENT



Model	GAK085Q7V	GAK104Q1V
Series	Gibson	
ENERGY STAR®		
<b>Performance</b>		
BTU (Cool)	8,000	10,000
Dehumidification (Pints / Hour)	2.2	2.8
Cool Area (Sq. Ft.)	350	490
EER	10.5	9.5
<b>Electrical</b>		
Volts	115	115
Amps (Cool)	6.7	9.2
Watts (Cool)	760	1,050
Length of Power Cord	6'	6'
Plug Type (NEMA)*	LCDI (A)	LCDI (A)
<b>Features</b>		
Controls	Electronic	Electronic
Fan Speeds (Cool / Fan / Heat)	3 / 3 / -	3 / 3 / -
Low Voltage Start-Up	•	•
Auto Cool Function	•	•
Energy Save	•	•
Sleep Mode	•	•
Filter Check	•	•
24 Hour On / Off Timer	•	•
Remote Control	Full-Function	Full-Function
Air CFM (High / Med / Low)	254 / 218 / 196	328 / 301 / 273
Air Direction Control	4-Way	4-Way
Fresh Air / Exhaust Vent / Closed	No / Yes / Yes	No / Yes / Yes
Filter Type	Antibacterial Mesh	Antibacterial Mesh
Filter Access	Slide-Out	Slide-Out
Cabinet Louvers	•	•
Rear Grille	•	•
Window Mounting Kit	Easy Mount	Easy Mount
<b>Dimensions</b>		
A - Cabinet Height	20-1/4"	20-1/4"
B - Cabinet Width	14-1/4"	14-1/4"
C - Cabinet Depth (with Front)	23 (24-1/2")	23 (24-1/2")
D - Window Height (Min. / Max.)	21-1/2" / 40"	21-1/2" / 40"
E - Window Width (Min.)	15-1/2"	15-1/2"
F - Max. Wall Thickness	8-1/2"	8-1/2"
Carton Height	25-3/4"	25-3/4"
Carton Width	18-1/4"	18-1/4"
Carton Depth	26-1/2"	26-1/2"
Unit Weight	80 Lbs.	90 Lbs.
Shipping Weight	95 Lbs.	105 Lbs.
<b>UPC (0-12505)</b>	27258-5	27259-2

## INSTALLATION

The following dimension and cutout information is for planning purposes only. For complete installation details consult manual packed with product, or download manual at Customer Service, online at [frigidaire.com](http://frigidaire.com).

\* Plug Type (NEMA)



(A)  
5-15P



### Slider / Casement Models

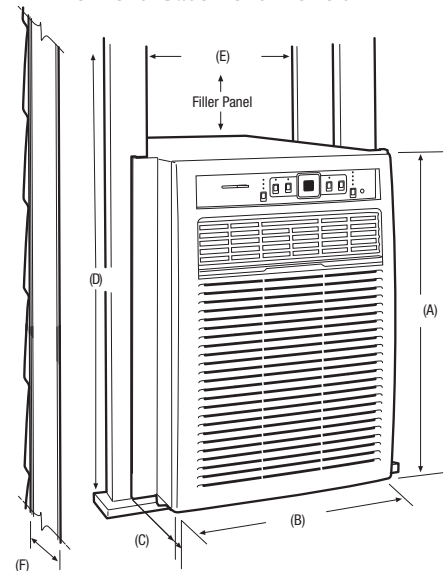

## Home Comfort Accessories



### Attractive Architectural Grille (EA109T)

Installs from inside the room! Heavy-duty, heavy-gauge, anodized aluminum grille stands up to the toughest wear and tear. The rear grille kit can be ordered for all through-the-wall models.



### Through-The-Wall Builder Sleeve (EA108T)

All-weather, galvanized steel with internal support provides security on the outside and beauty on the inside. Includes weather-tight seal, adjustable mounting brackets and protective aluminum rear grille.

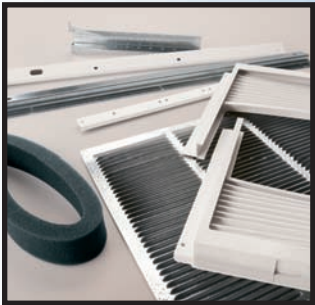

### Window Mounting Kit for Through-The-Wall Models (EA102T)

Adapts Gibson® Through-The-Wall models for window installation. Pleated quick mount side panels are specially treated to resist deterioration caused by the sun's damaging ultraviolet rays. Includes rear grille. Fits windows 28" to 41" wide, minimum 17-1/2" high.

## Gibson® Home Comfort

### FULL ONE-YEAR WARRANTY

Every Electrolux Major Appliances room air conditioner is guaranteed to be free of materials defects or component malfunctions. Electrolux Major Appliances will repair, without charge, any problem that occurs during the first year after original date of purchase.\*

### LIMITED 2<sup>ND</sup> - 5<sup>TH</sup> YEAR WARRANTY

#### Sealed Refrigeration System

Electrolux Major Appliances will provide a replacement for any defective part(s) in the Sealed Refrigeration System (compressor, condenser, evaporator and tubing) that breaks due to defects in materials or workmanship (not consumer abuse), for the second through fifth years from original date of purchase.\* Diagnostic, transportation and labor costs which are required because of service are the responsibility of the consumer.

*\*Some restrictions may apply for Alaska.*

This warranty is provided by Electrolux Major Appliances North America, a division of Electrolux Home Products Inc. in the U.S.A., and in Canada by Electrolux Canada Corp. For complete warranty details, please refer to your Owner's Manual.

High standards of quality at Electrolux Major Appliances mean we are constantly working to improve our products. We reserve the right to change specifications or discontinue models without notice.

### PARTS AND SERVICE

Wherever you live or move in the U.S.A., our national network of authorized independent service companies provide prompt, professional repair service. To maintain warranties, always ask for Electrolux Major Appliances Genuine Renewal Parts.



## Gibson®

USA  
Electrolux Major Appliances, North America  
250 Bobby Jones Expressway, Martinez, GA 30907  
1-800-944-9044

CANADA  
Electrolux Canada Corporation  
5855 Terry Fox Way, Mississauga, ON L5V 3E4  
1-800-265-8352

### Electrolux Major Appliances, N.A.

Every Gibson® appliance is backed by the global strength of the Electrolux Group, the world's largest manufacturer of kitchen and cleaning appliances.