

PERFORMANCE DATA NO LOAD & NO DOOR OPENINGS AT MID-POINT CONTROL SETTING	
Capacitor Run or Induction Run	65°F (18°C) Ambient
Operating Time	25 to 35%
Freezer Temperature	2° to 8°F (-17° to -13°C)
Refrigerator Temperature	35° to 40°F (2° to 4°C)
Low Side Pressure (cut-in)	8 to 16 psig (55 to 110 kPa)
Low Side Pressure (cut-out)	1 to 4 psig (7 to 28 kPa)
High Side Pressure (last 1/3 cycle)	110 to 120 psig (758 to 827 kPa)
Wattage (last 1/3 cycle)	140 to 185
Amps (running)	1.1 to 1.6
Base Voltage	115 vac (127 vac max)

DEFROST SPECIFICATIONS			
Cabinet Size	Thermostat		Ohms
	Cut-in	Cut-out	
18', 20' & 21'	9°F (-2°C)	50°F (10°C)	35
15' & 16'	29°F (-2°C)	50°F (10°C)	41

Mechanical Timer - Defrost 30 minutes every 10 hours of compressor run time.
Electronic Timer (ADC) - Defrost up to 24 minutes every 6-72 hours of compressor run time.

CONDENSER FAN MOTOR	
Watts	RPM
2.3	1100 CW Opposite Shaft

ICE MAKER SPECIFICATIONS		
Electrical	115 vac (127 vac max)	60 Hertz
Thermostat	Ice maker with black housing	Opens at 52°F (11°C) Closes at 12°F (-11°C)
	Ice maker with white housing	Opens at 48°F (8.9°C) Closes at 9°F (-12.8°C)
Heater Wattage	165 W	

ICE MAKER CONNECTOR PLUG CONNECTIONS	
Wire Number	Wire Color
1	Green / Yellow
2	Yellow
3	Black
4	Light Blue

SERVICE DATA SHEET

241588207

STANDARD - AUTOMATIC DEFROST TOP MOUNT FREEZER - R134a

IMPORTANT SAFETY NOTE

The information provided herein is designed to assist qualified repair personnel only. Untrained persons should not attempt to make repairs due to the possibility of electrical shock. Disconnect power cord before servicing this appliance.

IMPORTANT

If any green grounding wires are removed during servicing, they must be returned to their original position and properly secured.

NOTE

Some products come equipped with an Electronic Defrost Control. To initiate defrost, depress the fresh food light switch 5 times in 6 seconds (light bulb must be working). To terminate defrost, depress the fresh food light switch 5 times in 6 seconds.

CAUTION

All electrical parts and wiring must be shielded from torch flame. DO NOT allow torch to touch insulation; it will char at 200°F and flash ignite (burn) at 500°F. Excessive heat will distort the plastic liner.

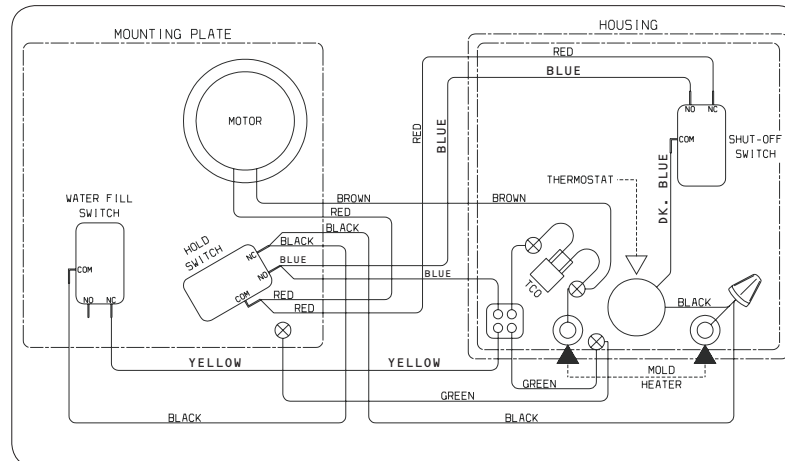

IMPORTANT

PLEASE RETURN THIS SHEET TO ITS ORIGINAL LOCATION.

ICE MAKER INFORMATION

Test Cycling: Remove cover by inserting screwdriver in notch at bottom and prying cover from housing. Use screwdriver to rotate motor gear counterclockwise until holding switch circuit is completed. All components of ice maker should function to complete the cycle.

Water Fill Volume: The water fill adjustment screw will change the fill time. One full turn is equal to 20cc (.68 oz.). The correct fill is 102 to 130cc (3.4 to 4.3 oz.). When a water valve is replaced, the fill volume must be checked.

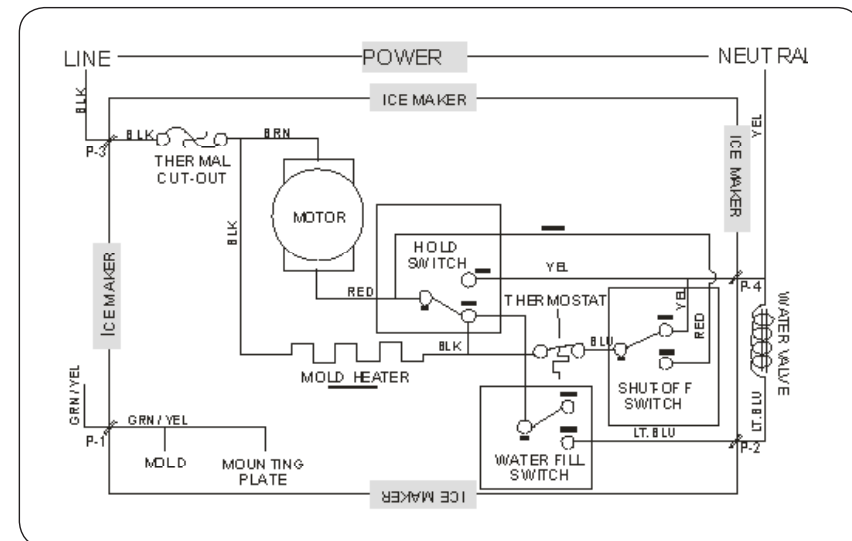
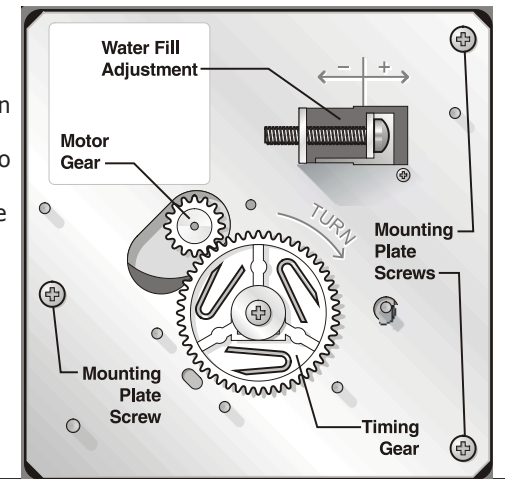

FREEZER COMPARTMENT

MACHINE COMPARTMENT

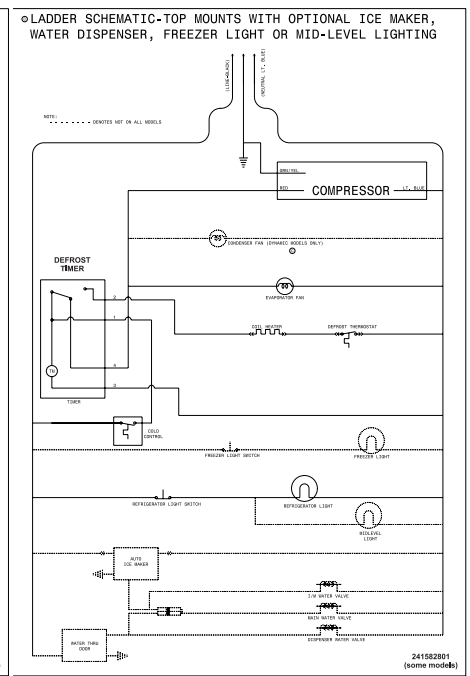
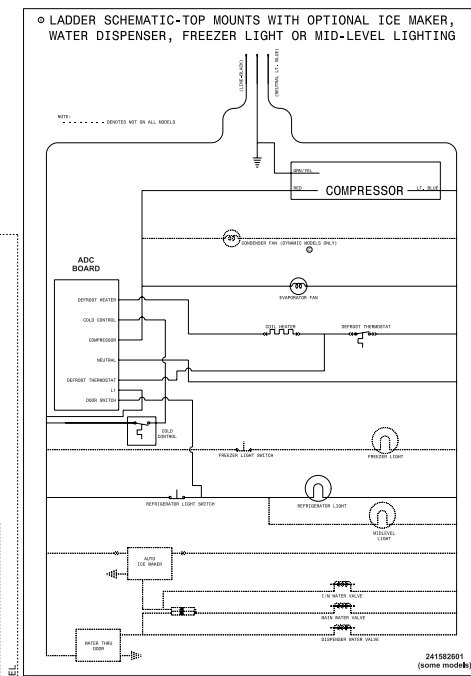
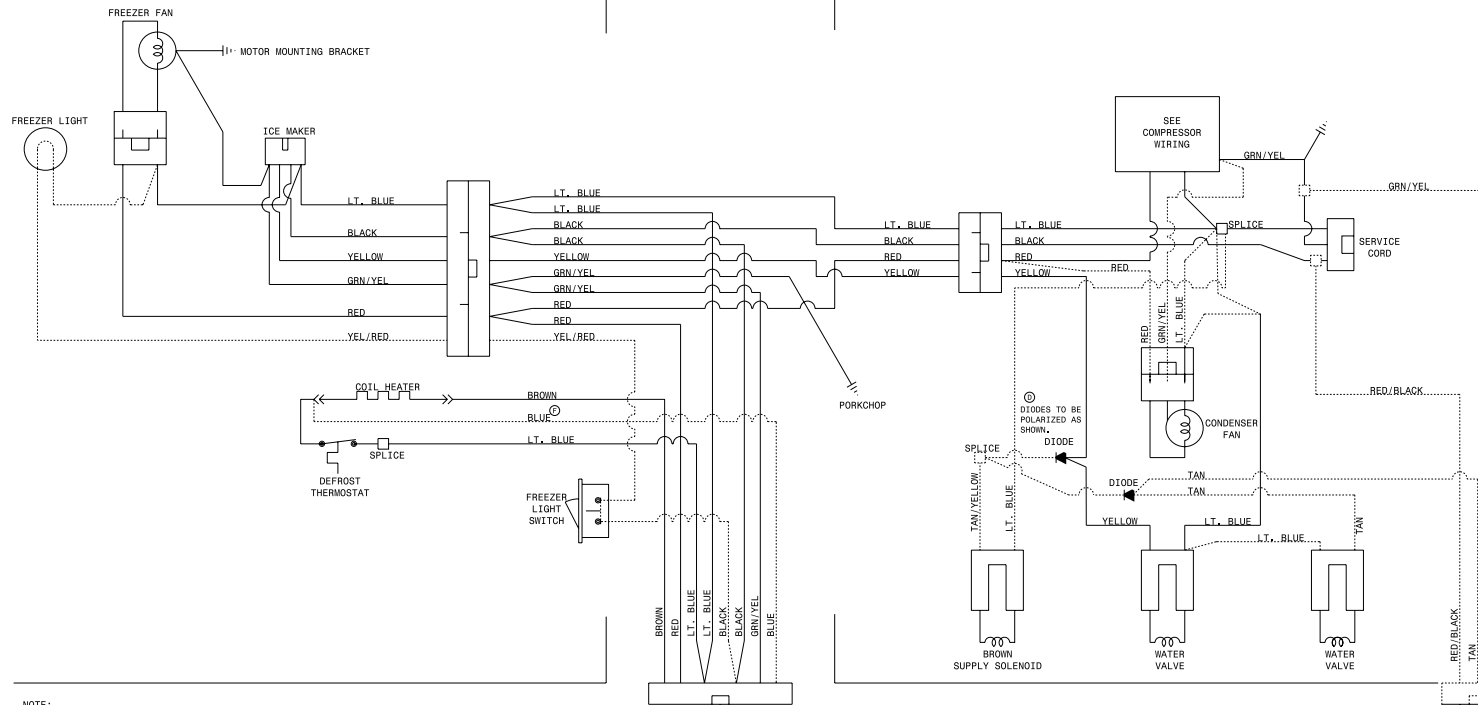

NOTE: - - - - - DENOTES NOT ON ALL MODELS.

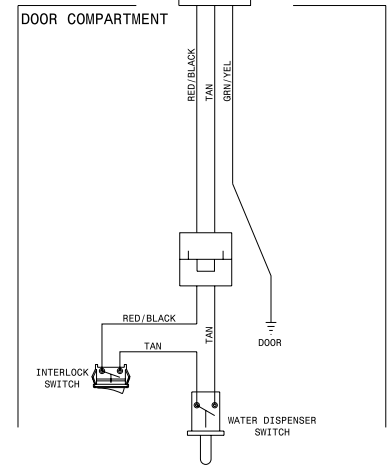
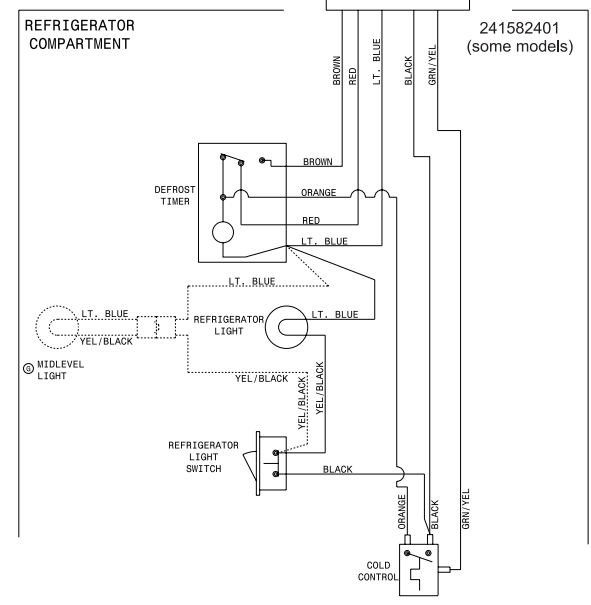
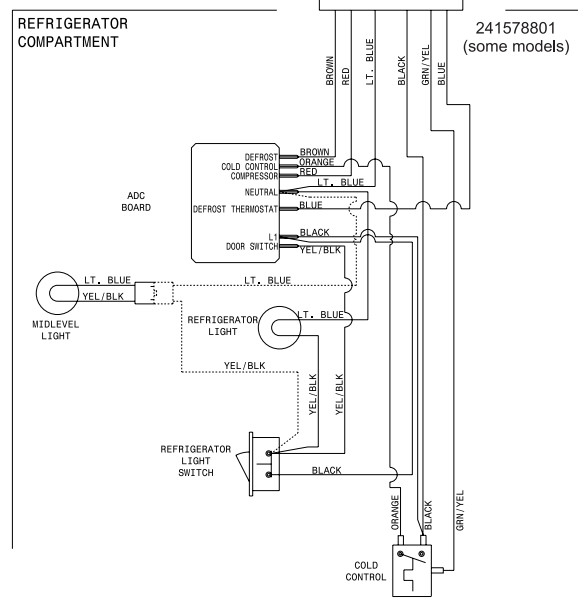

COMPRESSOR WIRING

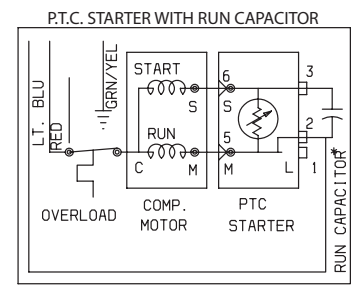
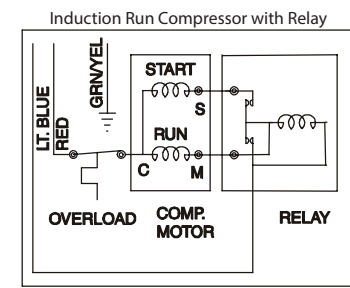

* CAPACITOR IS ONLY USED WITH SOME P.T.C. MODELS.