

1215R • 15" Solid Door Refrigerator • 1000 Series

FEATURES & BENEFITS



STAINLESS SOLID



INTEGRATED SOLID



BLACK SOLID

PERFORMANCE	<ul style="list-style-type: none"> • Volume of 2.9 cu ft holds up to 57 bottles (12 oz) or 92 cans (12 oz) • Digital Touch Pad Control is conveniently located on upper face of unit • Temperature range: 34°F - 45°F • Maintains temperature to within 1°F of the set point to maximize preservation
INTERIOR/EXTERIOR	<ul style="list-style-type: none"> • White interior is illuminated with LED lighting • Three removable tempered glass shelves • Standard commercial stainless steel handle is interchangeable with professional handle accessory • Door swing is field reversible
INTEGRATION	<ul style="list-style-type: none"> • Unit is designed to be built-in or can be freestanding • Integrated model requires 3/4" custom door panel • Four independently adjustable leveling legs provide a precise undercounter fit • Available in the following finishes: Stainless, Integrated & Black

MODEL DETAILS

Model	Voltage	Door Swing	Finish	Shipping Weight
U-1215RS-00A	115	Field Reversible	Stainless Solid	83 lbs
U-1215RINT-00A	115	Field Reversible	Integrated Solid	80 lbs
U-1215RB-00A	115	Field Reversible	Black Solid	83 lbs

ACCESSORIES

Model	Description	Finish	Shipping Weight
23074	Professional Door Handle, 1 1/4" Diameter	Stainless	2 lbs
23073	Commercial Door Handle, 7/8" Diameter	Stainless	2 lbs

1000 Series • 15" Solid Door Refrigerator • 1215R

DIMENSIONS

Dimensions shown apply to all finishes, including Integrated (INT) models with 3/4" overlay panel/frame installed.

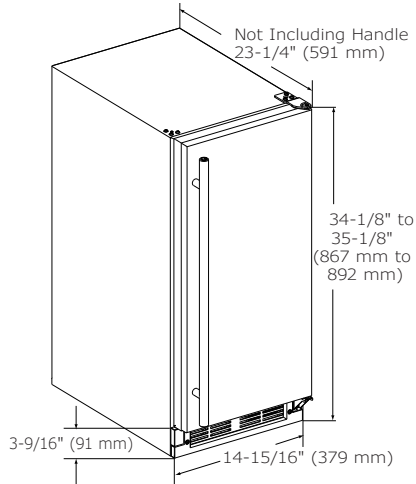

CABINET CUT-OUT

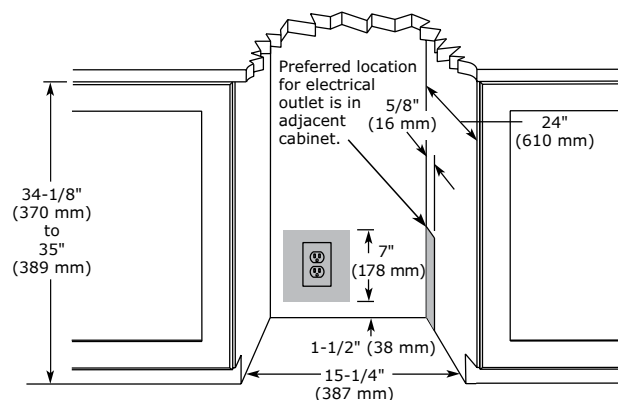

INSTALLATION NOTES

- When installing adjacent to wall, ensure 2 1/2" clearance on hinged side for 90° door opening, allowing ample room for door handle.
- Cutout includes the additional 1/4" width overall to ensure proper installation.
- No additional clearance around sides, top or rear of unit is needed for ventilation.
- Do not obstruct front grille air flow.

SPECIFICATIONS

Model	1215R
Amps: Running	1.2
Capacity: Bottle (12 oz)	57
Capacity: Can (12 oz)	92
Capacity: Volume (cu ft)	2.9
Control Type	Digital Touch Pad
Dimensions: Product Depth	23 1/4" / 591 mm
Dimensions: Product Height	34 1/8" / 867 mm
Dimensions: Product Width	14 15/16" / 379 mm
Energy Consumption: Avg. Per Year	225 kWh
ENERGY STAR	ENERGY STAR
Product Weight: Max	76 lbs
Refrigerant Type	R600a
Sabbath (Star K Certified)	Yes
Temperature Range	34°F - 45°F

COOLING SYSTEM



ELECTRICAL REQUIREMENTS

This unit requires a grounded a polarized 115 VAC, 60 Hz, 15 A power supply (normal household current).

Please visit u-line.com to view this model's User Guide. All specifications are subject to change without notice.



Residential & Commercial